

Lenses & Peripherals

# MV

## Machine Vision

General  
Catalog

SCS  
SOD-10X



# System Flow

## Lenses & Peripherals

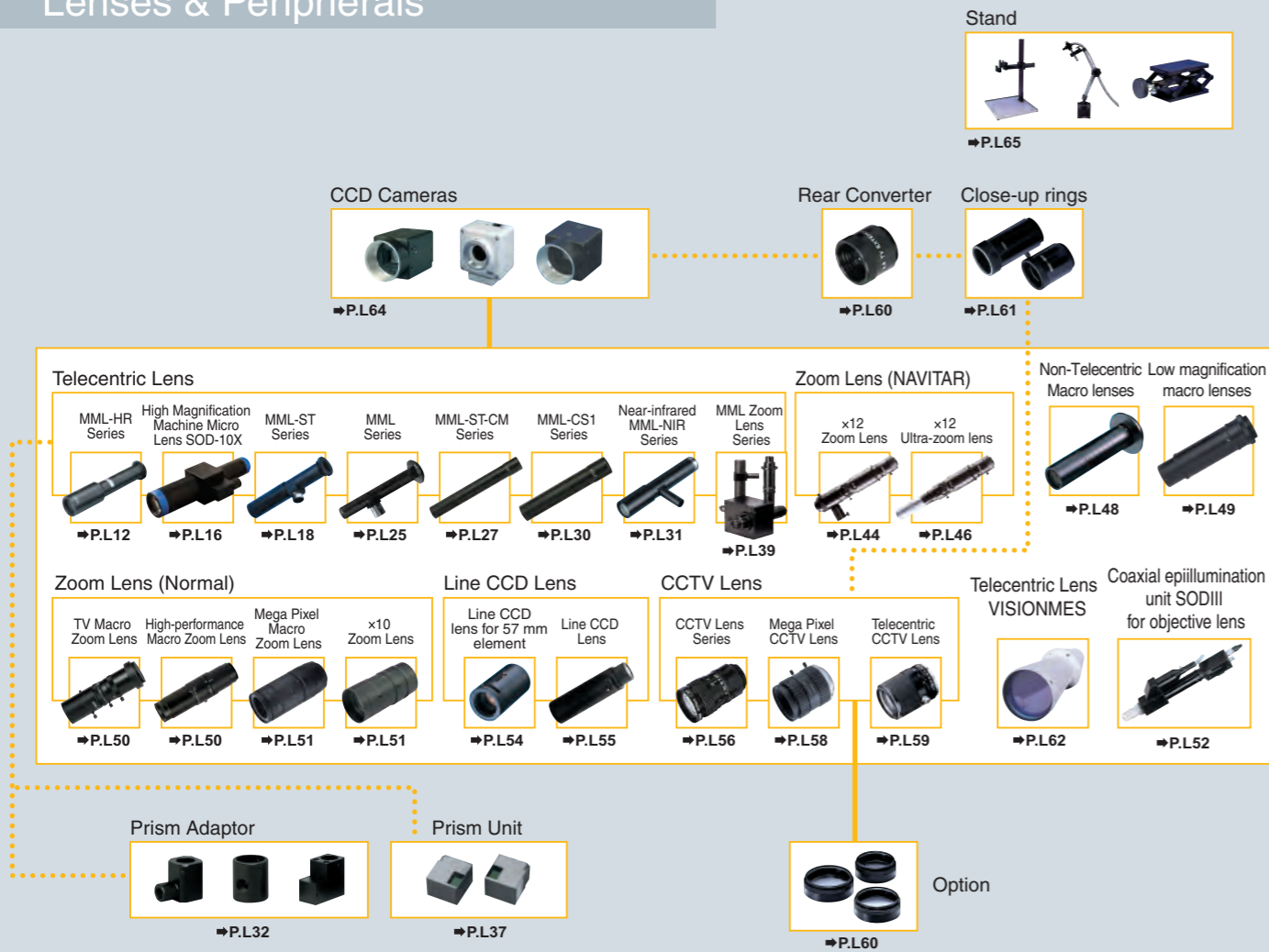

## Illumination Related Products

\*See "MV General Catalog - Illumination Related Products."



# INDEX

## MML Fixed Magnification Series

MML-HR Series	L-12
High Magnification Machine Micro Lens SOD-10X	L-16
MML-ST Series	L-18
MML Series	L-25
MML-ST-CM Series	L-27
MML-CS1 Series	L-30

## Near-infrared MML-NIR Series

## Prism Adaptor

## MML Zoom Lens Series

## Zoom Lens (NAVITAR)

x12 Zoom Lens	L-44
x12 Ultra-zoom lens	L-46

## Non-Telecentric Macro lenses

## Low magnification macro lenses

## Zoom Lens (Normal)

TV Macro Zoom Lens	L-50
High-performance Macro Zoom Lens	L-50
Mega Pixel Macro Zoom Lens	L-51
x10 Zoom Lens	L-51

## Coaxial Epillumination Unit SODIII for Object Lens

## Line CCD Lens

Line CCD Lens for 57 mm Element	L-54
Line CCD Lens	L-55

## CCTV Lens

CCTV Lens Series	L-56
Mega Pixel CCTV Lens	L-58
Telecentric CCTV Lens	L-59

## Option

## Telecentric Lens VISIONMES

## Peripherals

## Data and Terms

## Field of View List

## Lighting Pattern

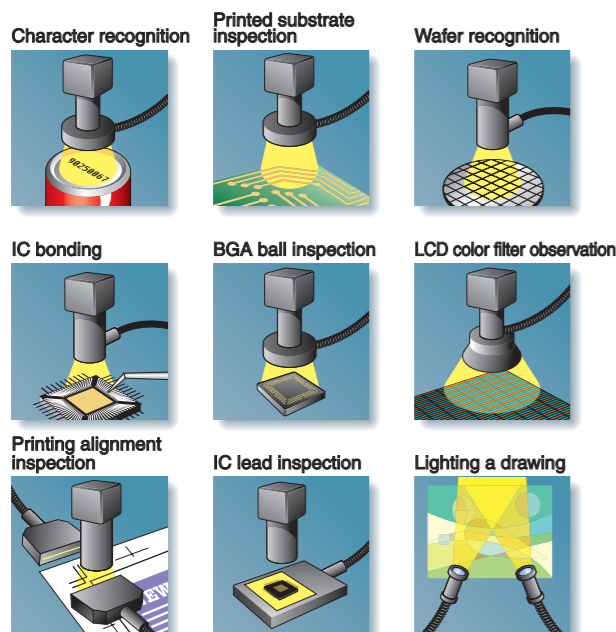

## Basic

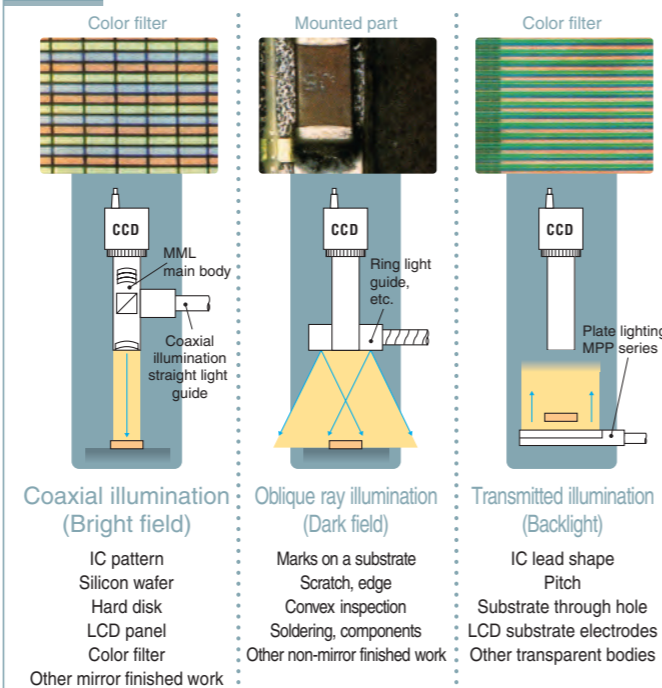

## Applied

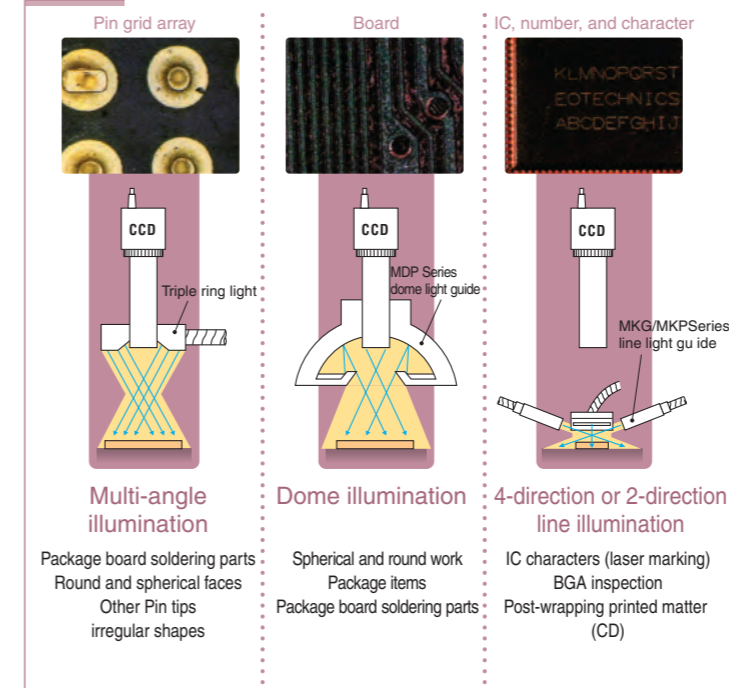

Not all dimensions or tolerances are given in this catalog. For more detailed information, please ask for product specifications.

# Machine Micro Lens

## MML Series

The MML Series consists of high capability fixed magnification lenses that provide the optical qualities required for alignment or parts recognition. The series features compact and long-width design for the purpose of installation into machines.

- Telecentric optical system realizes low bending of the image.
- Equipped with a uniform coaxial incident illumination function that covers the entire field of vision.
- A variety of models are offered with differing WD and camera mounts.



- Mega Pixel
- Non-Distortion
- High Contrast

## MML-HR Series

### MML-High Resolution

The MML-HR Series supports mega pixel cameras with 410 thousand or more pixels. The series is designed for high resolution in all areas of the lens and for high contrast the emphasizes the difference in S/N. The quality of Moritex lenses exists in a difference in image quality that cannot be compared using only catalog specifications.

- A lineup offering the long-awaited WD of 110 mm in addition to a WD of 65 mm.
- Non-distortion design.
- High contrast design.
- An ultra-uniform coaxial incident illumination function model is set in all lens types.
- Achievement of thorough cost reductions through revisions of the design and manufacturing processes.



- Non-Distortion
- Low Cost
- Uniform Illumination of Image Surface

## MML-ST Series

### MML-Standard

The MML-ST Series has, through combination with a 410 thousand pixel camera, renewed the design and manufacturing processes with high level optical capabilities. Furthermore, compact models with a diameter from 16 and featuring long-depth design are available for installation into manufacturing equipment. This series is the next generation in machine vision, pursuing the highest level of optical capabilities and ease of use.

- 4 types of WD to match customer needs (65, 100, 150, 300 mm).
- Non-distortion design.
- An ultra-uniform coaxial incident illumination function model is set in all lens types.
- Achievement of thorough cost reductions through revisions of the design and manufacturing processes.



## MML-ST-CM Series

### MML-CS1 Series



The MML-ST-CM/CS1 Series consists of small diameter, light weight models that achieve fine pitch and small space through special mounting of compact camera heads.

[MM;-ST-CM: for use with diameter 17 mm (M15.5 P0.5) mount]

[MM;-CS1: for use with diameter 12 mm (M10.5 P0.5) mount]



## MML-Zoom Lens Series

The MML-Zoom Lens Series consists of high capability zoom lenses with coaxial incident illumination functions designed with telecentric optics. These lenses support all type of work recognition through the use of a wide zoom range and a long-width design, as well as uniform coaxial incident illumination that covers the entire field of vision. Zoom models include both a manual type and a power zoom type that includes a stepping motor.

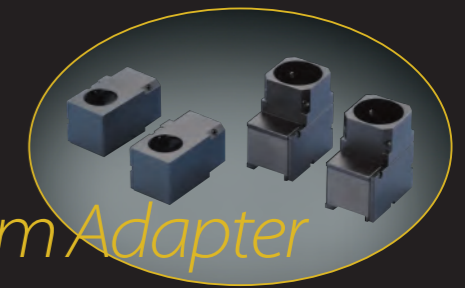

## Prism Adapter

These prism adapters are for the MML-ST Series. Prism adapters make it possible to bend the optical axis at a right angle of 90 degrees, and to perform mark recognition for microscopic work by modifying the pitch between 2 MML lenses to a fine pitch.

# Machine Micro Lens

## Non-Distortion

The pursuit of high capabilities with no aberration has resulted in the elimination of bending of the image. This means that it is no longer necessary to consider distortion offsets.

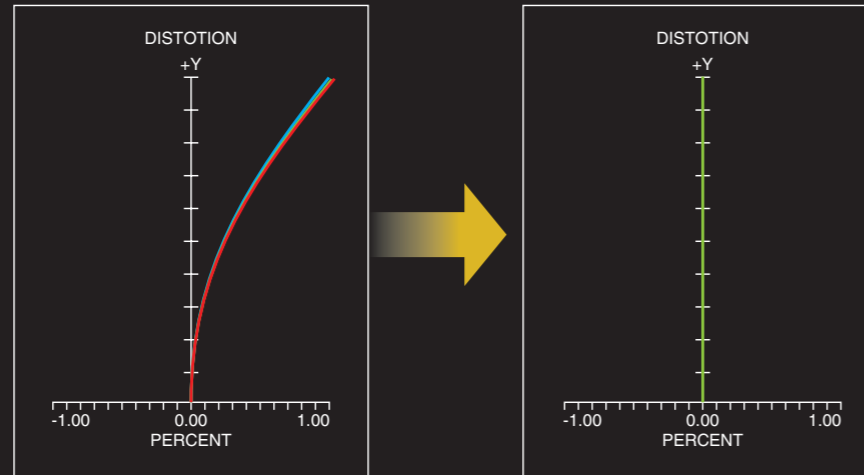

Conventional MML

MML-HR & MML-ST

## High Contrast

Improvement of contrast has made possible image recognition with greater emphasis on the shadings of black and white. By converting the resolution chart image to binary form and then graphing and comparing the brightness levels, it can be observed that the MML-HR greatly emphasizes the difference in brightness between black and white when compared to conventional Mega MML.

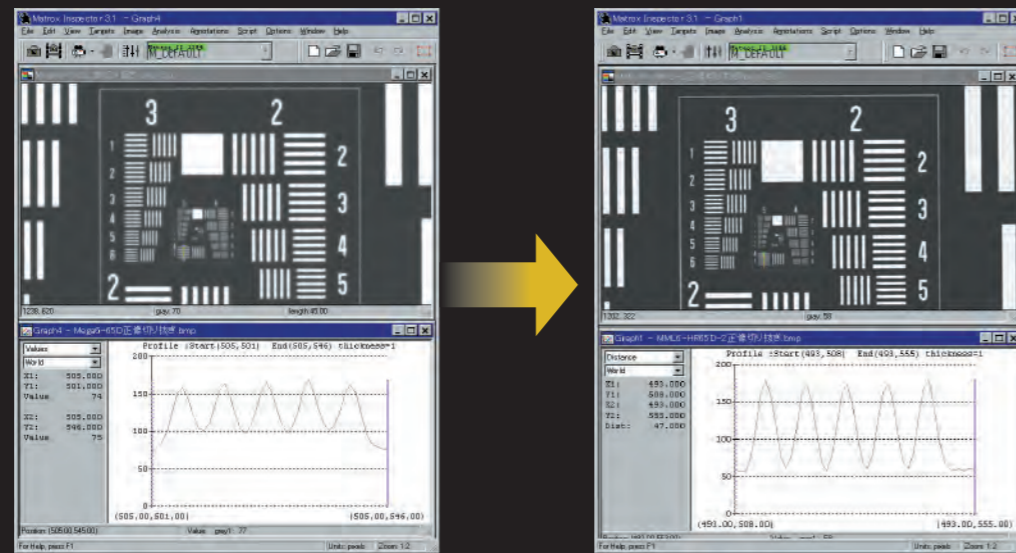

Conventional MML

MML-HR & MML-ST

## Design Concept

Pixel size, resolution limitation frequency, Fno relation

The MML-HR/ST series consists of two type of optical designs combined with CCD cameras.

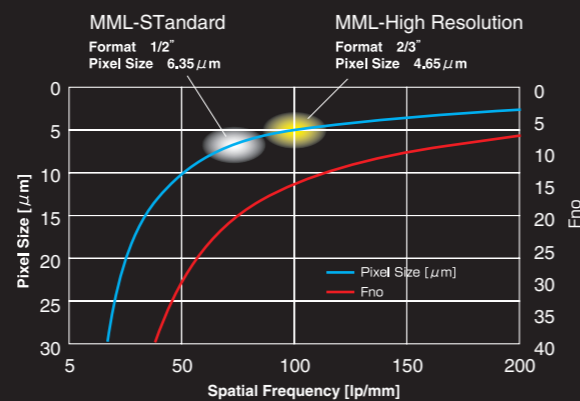

## Illumination Uniformity

However, in this type of use, the brightness of the center of the screen is raised due to reflection from the lens of the illumination light. The ST/HR Series solves this problem with a design that vastly reduces reflection from the lens. This improves the uniformity of lighting for the image surface for even mat-shaped work.

Recognition using coaxial incident illumination was performed for microcomputer surfaces (rough surfaces). The MML-ST/HR brightness graph shows that the difference in brightness at the center and periphery of the screen is very small, and the highlight area has been removed from the center of the image itself.

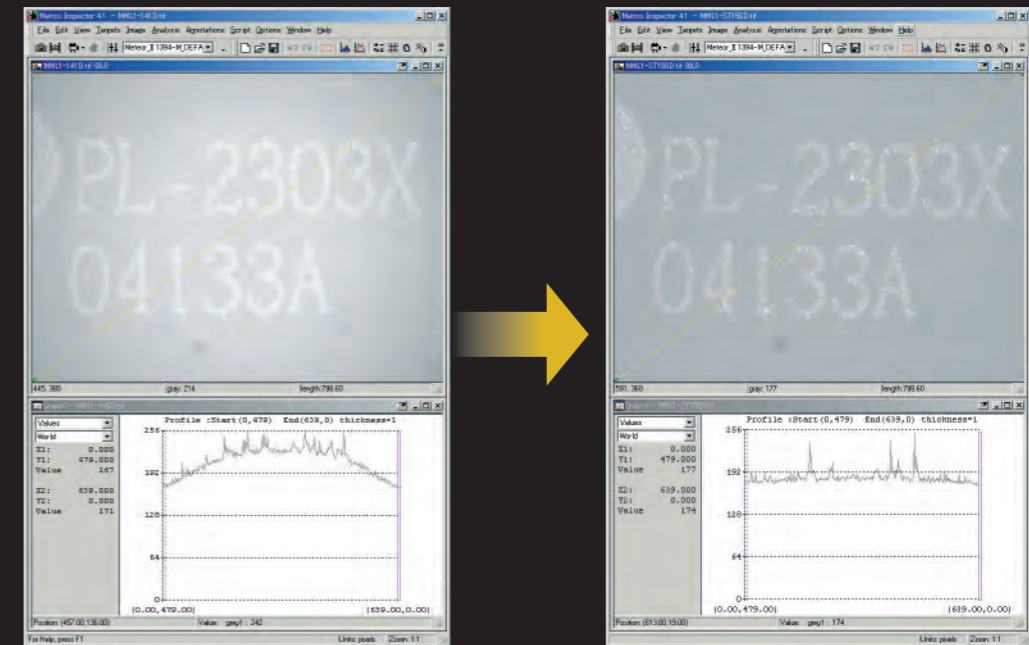

Conventional MML

MML-HR & MML-ST

## C Mount

## 3 Mounts of Differing Type

Diameter 34 Ring Type MML

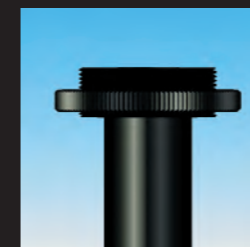

Diameter 30 Ring Type MML-ST / HR

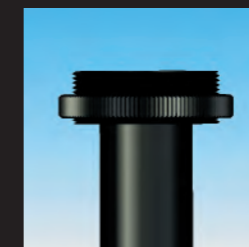

Screw Type MML-ST



Moritex provides custom response to requests for modifications of mounts and special mounts.



# MML-HR Series

MML-High Resolution

MML-HR Series



- Supports mega pixel CCD.
  - High resolving power throughout the field of view
  - Number of pixels: 410 thousand pixels~mega pixels
- Compatible with 2/3" or smaller CCD element (some only to 1/2")

The MML-HR Series is a high capability model that supports mega pixel cameras with 410 thousand pixels or more (4.65 μm/Pix~).

The entire screen features a high resolution and high contrast design that realizes amazing, ultra-high image quality which cannot be compared through numbers alone. This series exerts true power in highly detailed inspections and alignments.

## WD65mm.....

Product name	Magnification	WD	Resolution	Depth of field	NA	Effective Fno	TV distortion	Largest compatible CCD	Weight	Mount	Commodity code
<b>MML05-HR65D</b>	×0.5	65mm	12.8μm	3.04mm	0.026	9.5	-0.001%less	2/3"	75g	C Mount	A-3029
<b>MML1-HR65D</b>	×1.0	65mm	7.5μm	0.88mm	0.045	11	-0.02%	2/3"	58g	C Mount	A-3031
<b>MML1.5-HR65D</b>	×1.5	65mm	5.4μm	0.42mm	0.063	12	-0.036%	1/2"	53g	C Mount	A-3032
<b>MML2-HR65D</b>	×2.0	65mm	4.5μm	0.27mm	0.074	13.5	0.02%	2/3"	52g	C Mount	A-3033
<b>MML4-HR65D</b>	×4.0	65mm	3μm	0.09mm	0.112	17.9	0.018%	2/3"	94g	C Mount	A-3034
<b>MML6-HR65D</b>	×6.0	65mm	~3μm	0.06mm	0.112	26.7	0.006%	2/3"	102g	C Mount	A-3035
<b>MML4-HR65D-VI</b>	×4.0	65mm	3~13.3μm	0.09~0.53mm	0.112	17.9~79.2	0.018%	2/3"	95g	C Mount	A-3094
<b>MML6-HR65D-VI</b>	×6.0	65mm	3~13.9μm	0.06~0.58mm	0.112	26.7~124	0.006%	2/3"	102g	C Mount	A-3095

\*Resolution indicates a theoretical resolution at a wavelength of 550nm.

\*Depth of field is calculated assuming a horizontal 320 TV resolution using a 1/2" CCD camera. (Permissible circle of confusion on the image-formation side: 40μm)

### Model Explanation

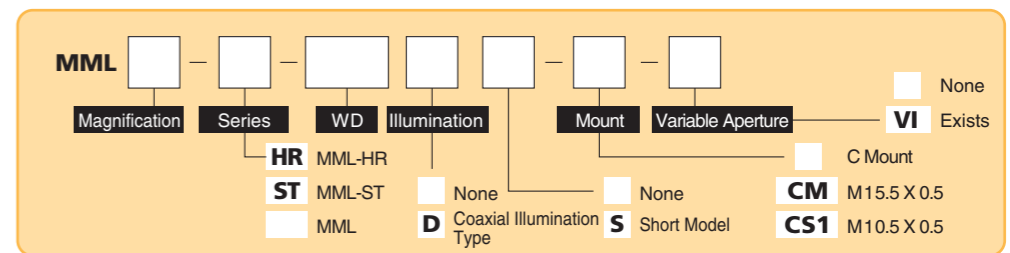

### MML-HR Series

**MML05-HR65D**

**MML1-HR65D**

**MML1.5-HR65D**

**MML2-HR65D**

**MML4-HR65D**

**MML6-HR65D**

**MML4-HR65D-VI**

**MML6-HR65D-VI**



MML-HR Series

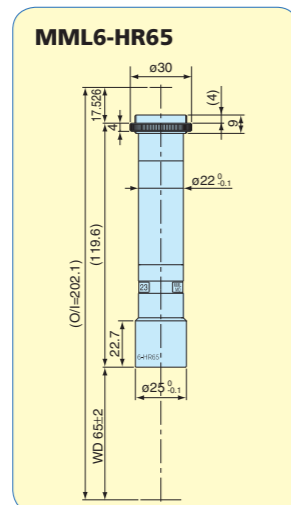
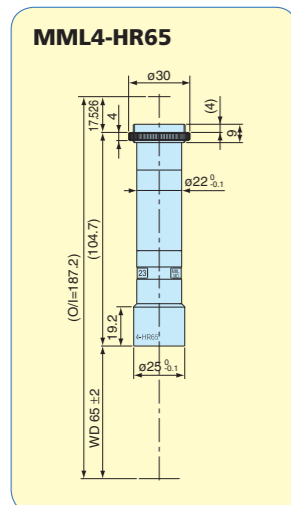
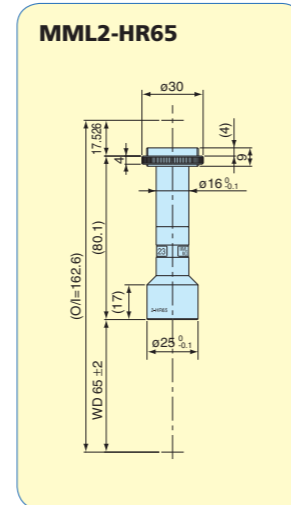
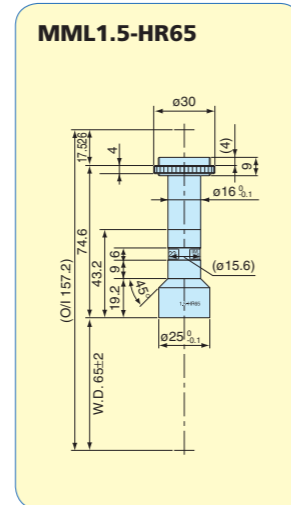
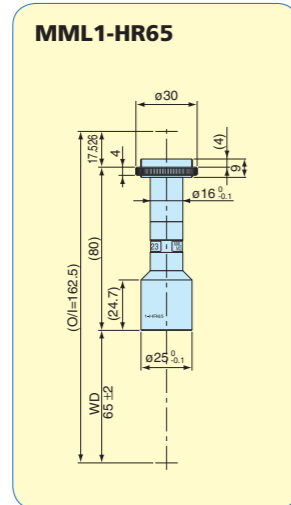
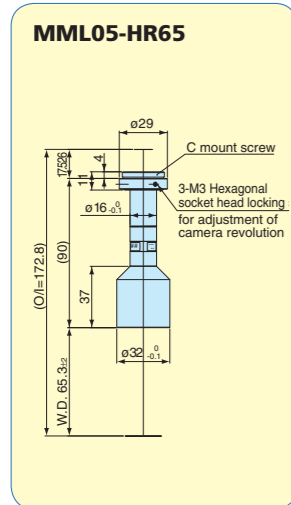

Product name	Magnification	WD	Resolution	Depth of field	NA	Effective Fno	TV distortion	Largest compatible CCD	Weight	Mount	Commodity code
MML05-HR65	x0.5	65mm	12.8μm	3.04mm	0.026	9.5	-0.001%	2/3"	70g	C-mount	A-3044
MML1-HR65	x1.0	65mm	7.5μm	0.88mm	0.045	11	-0.02%	2/3"	50g	C-mount	A-3045
MML1.5-HR65	x1.5	65mm	5.4μm	0.42mm	0.063	12	-0.036%	1/2"	46g	C-mount	A-3046
MML2-HR65	x2.0	65mm	4.5μm	0.27mm	0.074	13.5	0.02%	2/3"	46g	C-mount	A-3047
MML4-HR65	x4.0	65mm	3μm	0.09mm	0.112	17.9	0.018%	2/3"	86g	C-mount	A-3048
MML6-HR65	x6.0	65mm	3μm	0.06mm	0.112	26.7	0.006%	2/3"	94g	C-mount	A-3049

\*Resolution values are for theoretical resolution at a wavelength of 550 nm.  
 \*Field depth values were calculated assuming a resolution equivalent to 1/2" CCD horizontal 240 TV display resolution (permitted circle of confusion diameter 40 μm).

Newly Released  
MML-PL25HR

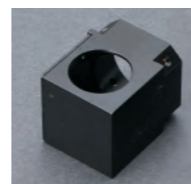

Dedicated 90 degree prism for MML-HR Refer to page L36 for details

MML-HR Series

WD110mm

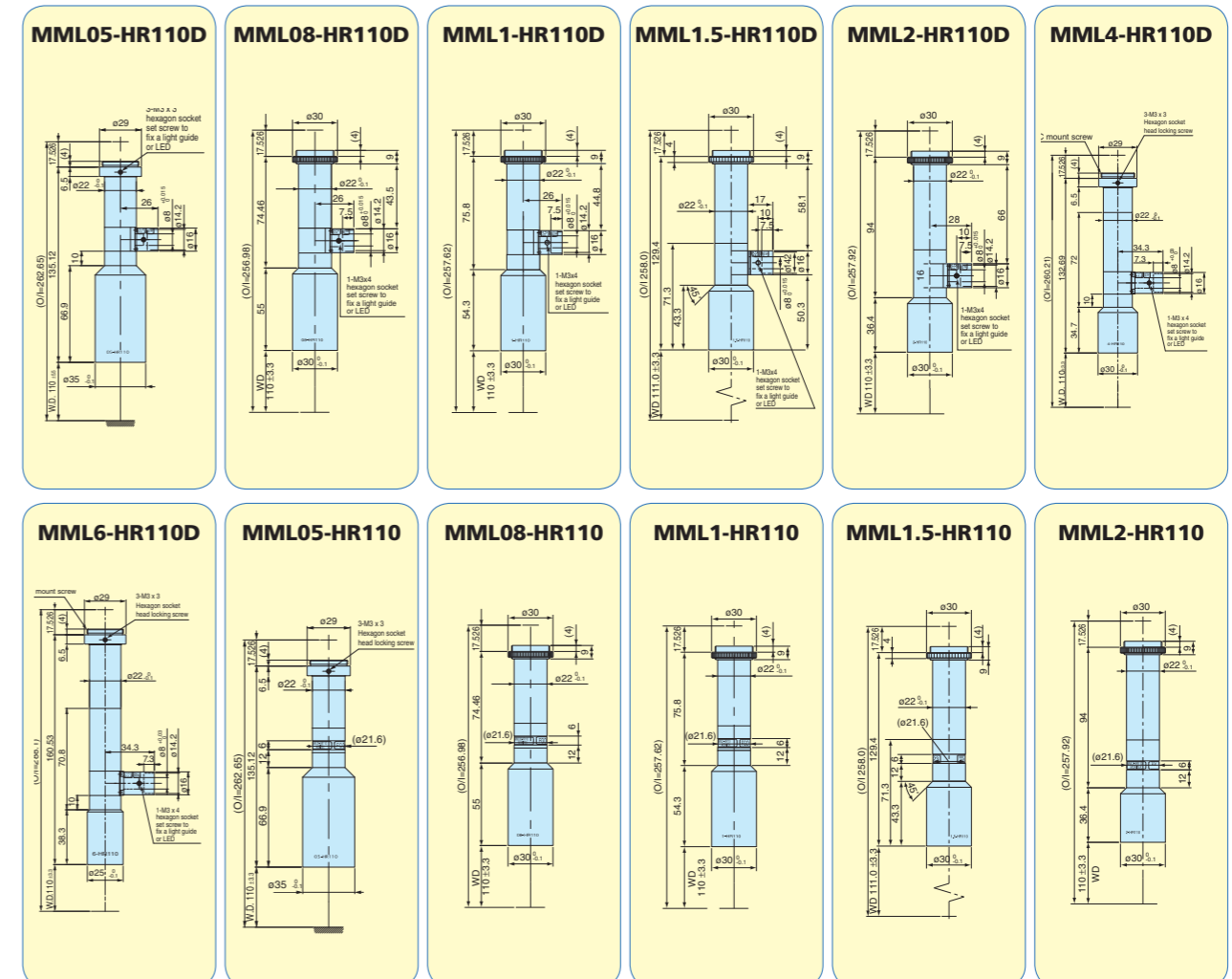

Product name	Magnification	WD	Resolution	Depth of field	NA	Effective Fno	TV distortion	Largest compatible CCD	Weight	Mount	Commodity code
MML05-HR110D	x0.5	110.0mm	12.8μm	3.0mm	0.026	9.5	0.018%	2/3"	142g	C-mount	A-3037
MML08-HR110D	x0.8	110.0mm	9.3μm	1.4mm	0.036	11	0.009%	2/3"	112g	C-mount	A-3038
MML1-HR110D	x1.0	110.0mm	7.4μm	0.88mm	0.045	11	0.003%	2/3"	120g	C-mount	A-3039
MML1.5-HR110D	x1.5	111.0mm	5.4μm	0.42mm	0.063	12	0.025%	2/3"	110g	C-mount	A-3040
MML2-HR110D	x2.0	110.0mm	4.5μm	0.27mm	0.074	13.5	0.014%	2/3"	110g	C-mount	A-3041
MML4-HR110D	x4.0	110.0mm	3.7μm	0.11mm	0.09	22.2	-0.001%	2/3"	125g	C-mount	A-3042
MML6-HR110D	x6.0	110.0mm	4.5μm	0.088mm	0.075	39.9	0.022%	2/3"	140g	C-mount	A-3043
MML05-HR110	x0.5	110.0mm	12.8μm	3.0mm	0.026	9.5	0.018%	2/3"	137g	C-mount	A-3051
MML08-HR110	x0.8	110.0mm	9.3μm	1.4mm	0.036	11	0.009%	2/3"	109g	C-mount	A-3052
MML1-HR110	x1.0	110.0mm	7.4μm	0.88mm	0.045	11	0.003%	2/3"	116g	C-mount	A-3053
MML1.5-HR110	x1.5	111.0mm	5.4μm	0.42mm	0.063	12	0.025%	2/3"	98g	C-mount	A-3054
MML2-HR110	x2.0	110.0mm	4.5μm	0.27mm	0.074	13.5	0.014%	2/3"	100g	C-mount	A-3055

\*Resolution values are for theoretical resolution at a wavelength of 550 nm.  
 \*Field depth values were calculated assuming a resolution equivalent to 1/2" CCD horizontal 240 TV display resolution (permitted circle of confusion diameter 40 μm).





MML-ST Series



# MML-ST Series

MML-Standard

MML-ST Series



- Compact design with a lens barrel diameter of 16~
- Long-width design
- Number of pixels: ~410 thousand pixels Element size: 1/2" or less

The MML-ST Series has, through combination with a 410 thousand pixel camera, renewed the design and manufacturing processes with high level optical capabilities. Furthermore, compact models with a diameter from 16 and featuring long-depth design are available for installation into manufacturing equipment.

MML-ST Series

## WD40mm

Product name	Magnification	WD	Resolution	Depth of field	NA	Effective Fno	TVdistortion	Largest compatible CCD	Weight	Mount	Commodity code
MML1-ST40D	x1.0	40.0mm	7.2μm	0.88mm	0.046	11.0	-0.013% or less	1/2"	31g	C Mount	A-3086
MML1.5-ST40D	x1.5	40.1mm	5.6μm	0.44mm	0.060	12.5	0.011% or less	1/2"	31g	C Mount	A-3088
MML2-ST40D	x2.0	40.1mm	4.8μm	0.29mm	0.070	14.3	0.006% or less	1/2"	34g	C Mount	A-3090
MML3-ST40D	x3.0	37.9mm	4.8μm	0.19mm	0.070	21.3	-0.049% or less	1/2"	33g	C Mount	A-3092
MML4-ST40D	x4.0	40.9mm	4.8μm	0.14mm	0.070	28.5	0.005% or less	1/2"	36g	C Mount	A-3077
MML6-ST40D	x6.0	40.3mm	4.8μm	0.10mm	0.070	42.8	-0.012% or less	1/2"	39g	C Mount	A-3079
MML8-ST40D	x8.0	40.0mm	4.8μm	0.07mm	0.070	57.0	-0.011% or less	1/2"	42g	C Mount	A-3081
MML1-ST40	x1.0	40.0mm	7.2μm	0.88mm	0.046	11.0	-0.013% or less	1/2"	26g	C Mount	A-3087
MML1.5-ST40	x1.5	40.1mm	5.6μm	0.44mm	0.060	12.5	0.011% or less	1/2"	26g	C Mount	A-3089
MML2-ST40	x2.0	40.1mm	4.8μm	0.29mm	0.070	14.3	0.006% or less	1/2"	29g	C Mount	A-3091
MML3-ST40	x3.0	37.9mm	4.8μm	0.19mm	0.070	21.3	-0.049% or less	1/2"	28g	C Mount	A-3093
MML4-ST40	x4.0	40.9mm	4.8μm	0.14mm	0.070	28.5	0.005% or less	1/2"	31g	C Mount	A-3078
MML6-ST40	x6.0	40.3mm	4.8μm	0.10mm	0.070	42.8	-0.012% or less	1/2"	35g	C Mount	A-3080
MML8-ST40	x8.0	40.0mm	4.8μm	0.07mm	0.070	57.0	-0.011% or less	1/2"	37g	C Mount	A-3082

\*Field depth values were calculated assuming a resolution equivalent to 1/2" CCD horizontal 240 TV display resolution (permitted circle of confusion diameter 40 μm).  
 \*Resolution values are for theoretical resolution at a wavelength of 550 nm.  
 Caution) The WD 40 mm series does not have a setting for the prism adapter option.



MML-ST Series

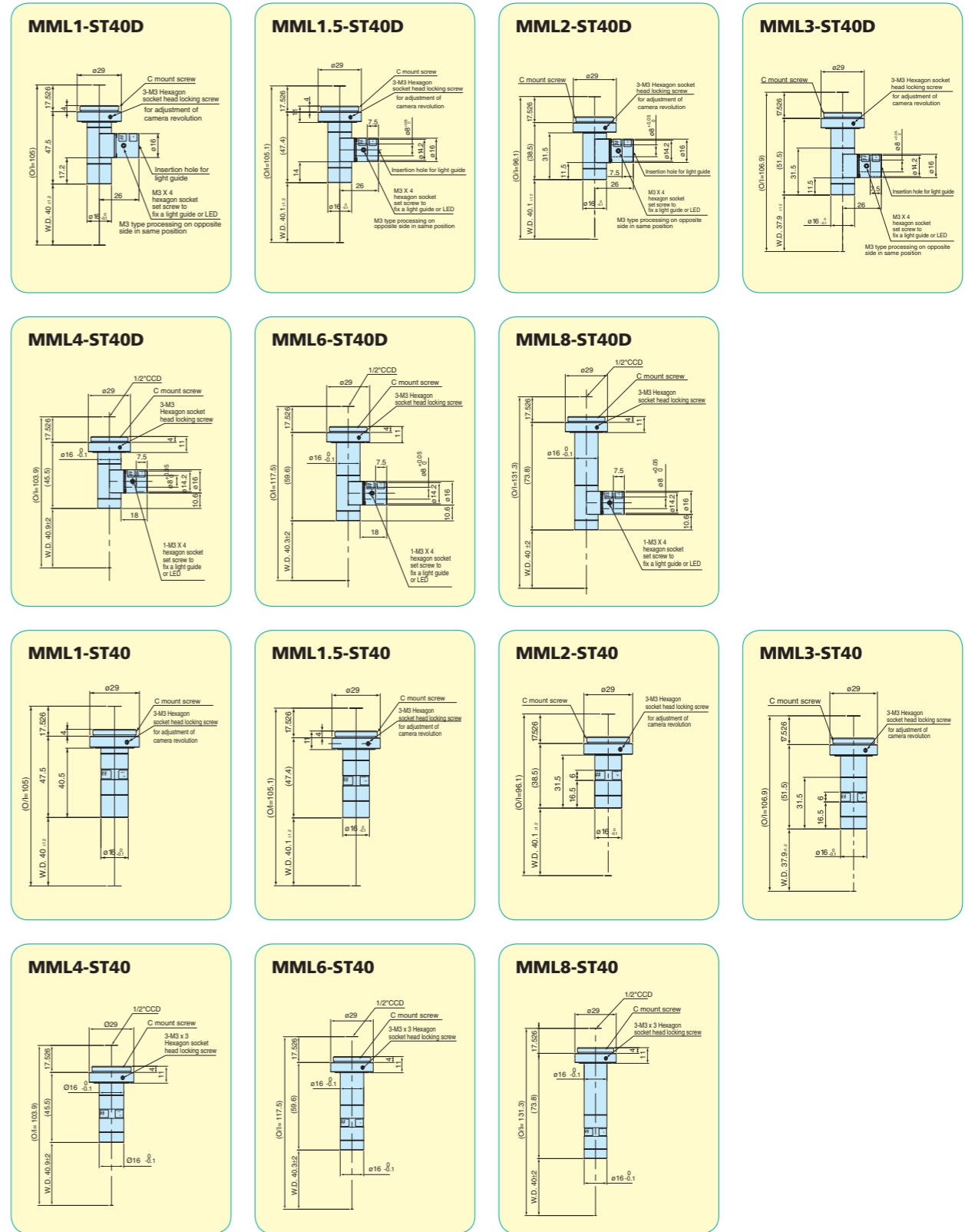

# WD65mm



MML-ST Series



MML-ST Series

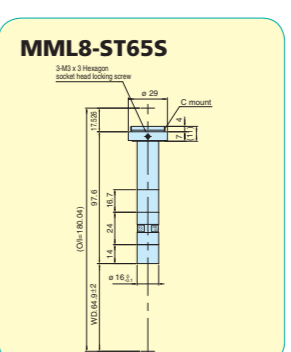
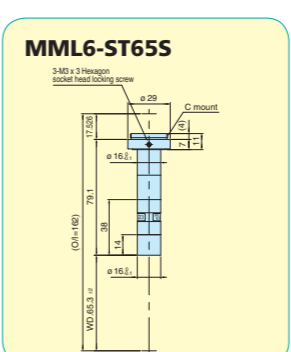
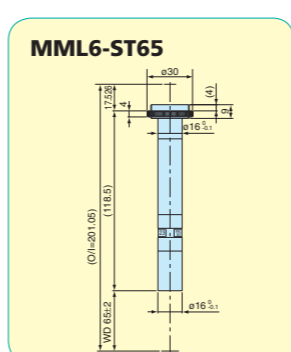
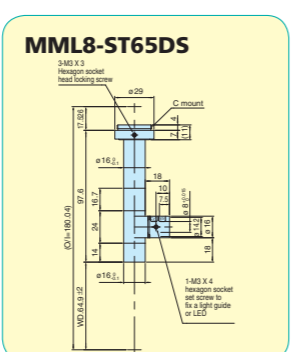
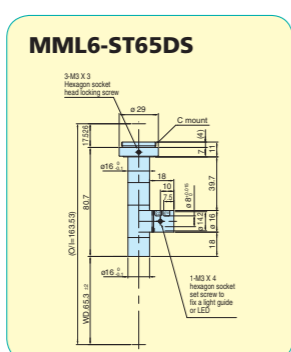
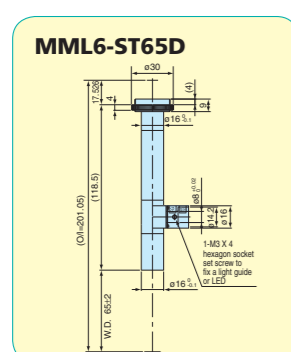
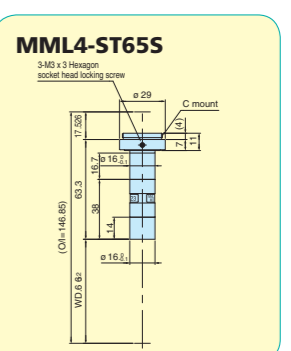
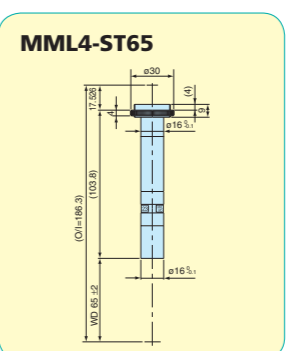
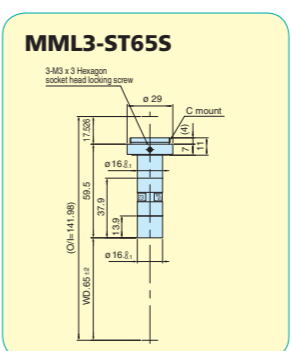
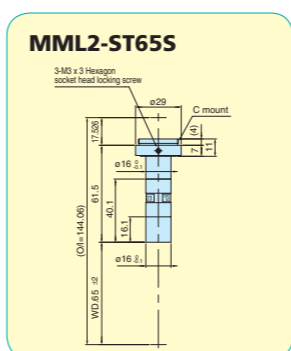
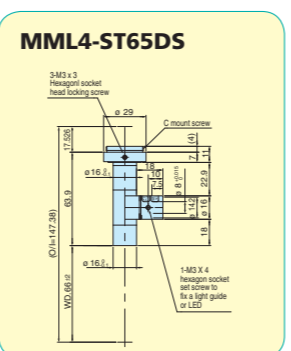
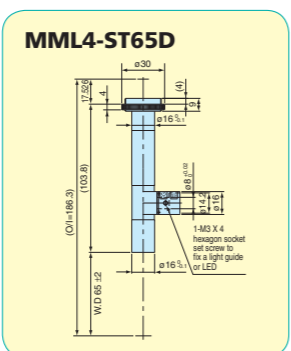
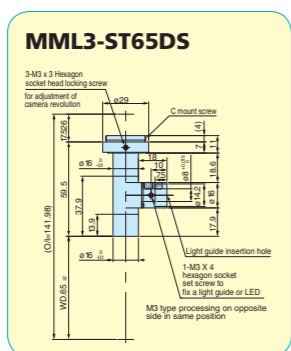
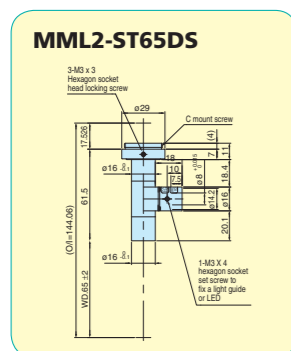
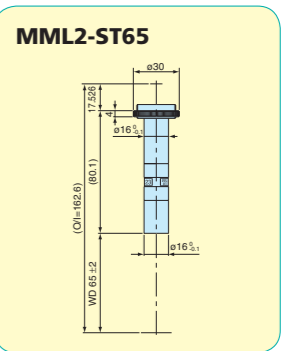
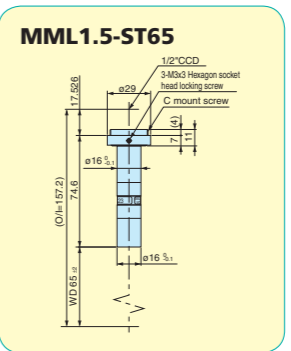
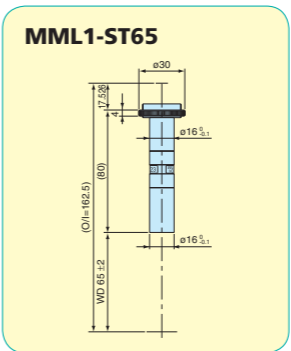
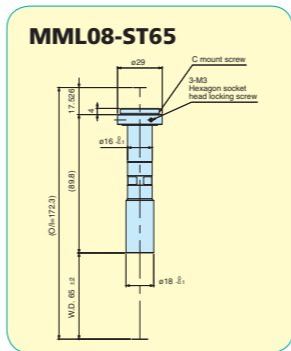
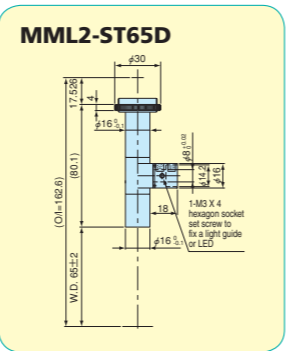
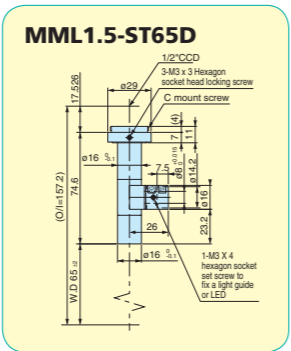
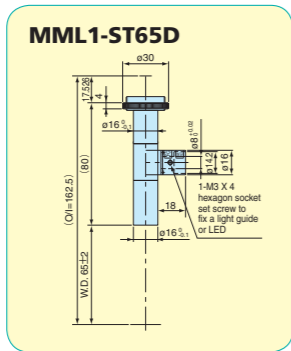
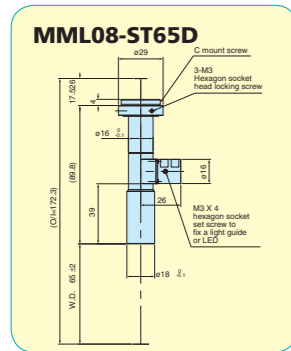

### Optical Specifications for Machine Types Recommended for Combination with the Rear Converter

Caution) If machines other than those recommended for combination are used, foreign objects and damage of the rear converter may be contained in the images. For this reason, do not use any machines other than the recommended types.

Product Name	Converter	Magnification	Resolution	Field Depth	Valid Fno
<b>MML1-ST65D/65</b>	<b>SOD-1.5X</b>	1.5 X	12.5μm	0.99mm	27.9
	<b>SOD-2X</b>	2.0 X	12.5μm	0.74mm	37.2
<b>MML1.5-ST65D/65</b>	<b>SOD-1.5X</b>	2.25X	7μm	370μm	23.4
	<b>SOD-2X</b>	3X	7μm	280μm	31.3
<b>MML2-ST65D/65</b>	<b>SOD-1.5X</b>	3 X	5.8μm	230μm	26
	<b>SOD-2X</b>	4 X	5.8μm	170μm	34.6

Product name	Magnification	WD	Resolution	Depth of field	NA	Effective Fno	TV distortion	Largest compatible CCD	Weight	Mount	Commodity code
<b>MML08-ST65D</b>	×0.8	65mm	12.4μm	1.86mm	0.027	14.9	0.0003%	1/2"	49g	C-mount	A-3011
<b>MML1-ST65D</b>	×1	65mm	12.5μm	1.49mm	0.027	18.6	0.002%	1/2"	44g	C-mount	A-3012
<b>MML1.5-ST65D</b>	×1.5	65mm	7μm	0.56mm	0.048	15.5	-0.036%	1/2"	43g	C-mount	A-3062
<b>MML2-ST65D</b>	×2	65mm	5.8μm	0.35mm	0.057	17.3	0.011%	1/2"	44g	C-mount	A-3013
<b>MML2-ST65DS</b>	×2	65mm	5.6μm	0.35mm	0.06	17.3	0.004%	1/2"	37g	C-mount	A-3101
<b>MML3-ST65DS</b>	×3	65mm	4.7μm	0.19mm	0.069	21.9	0.003%	1/2"	35g	C-mount	A-3102
<b>MML4-ST65D</b>	×4	65mm	4.6μm	0.135mm	0.073	27	0.0017%	1/2"	55g	C-mount	A-3014
<b>MML4-ST65DS</b>	×4	66mm	4.4μm	0.13mm	0.076	25.9	0.011%	1/2"	41g	C-mount	A-3103
<b>MML6-ST65D</b>	×6	65mm	4.6μm	0.091mm	0.073	40.9	0.0023%	1/2"	60g	C-mount	A-3015
<b>MML6-ST65DS</b>	×6	65.3mm	4.4μm	0.09mm	0.076	39.3	0.002%	1/2"	43g	C-mount	A-3104
<b>MML8-ST65DS</b>	×8	64.9mm	4.4μm	0.07mm	0.076	50	-0.003%	1/2"	46g	C-mount	A-3081

\*Field depth values were calculated assuming a resolution equivalent to 1/2" CCD horizontal 240 TV display resolution (permitted circle of confusion diameter 40 μm).  
\*Resolution values are for theoretical resolution at a wavelength of 550 nm.

Product name	Magnification	WD	Resolution	Depth of field	NA	Effective Fno	TV distortion	Largest compatible CCD	Weight	Mount	Commodity code
<b>MML08-ST65</b>	×0.8	65mm	12.4μm	1.86mm	0.027	14.9	0.0003%	1/2"	44g	C-mount	A-3085
<b>MML1-ST65</b>	×1	65mm	12.5μm	1.49mm	0.027	18.6	0.002%	1/2"	38g	C-mount	A-3025
<b>MML1.5-ST65</b>	×1.5	65mm	7μm	0.56mm	0.048	15.5	-0.036%	1/2"	36g	C-mount	A-3063
<b>MML2-ST65</b>	×2	65mm	5.8μm	0.35mm	0.057	17.3	0.011%	1/2"	38g	C-mount	A-3026
<b>MML2-ST65S</b>	×2	65mm	5.6μm	0.35mm	0.06	17.3	0.004%	1/2"	32g	C-mount	A-3105
<b>MML3-ST65S</b>	×3	65mm	4.7μm	0.19mm	0.069	21.9	0.003%	1/2"	30g	C-mount	A-3106
<b>MML4-ST65</b>	×4	65mm	4.6μm	0.135mm	0.073	27	0.0017%	1/2"	50g	C-mount	A-3056
<b>MML4-ST65S</b>	×4	66mm	4.4μm	0.13mm	0.076	25.9	0.011%	1/2"	36g	C-mount	A-3107
<b>MML6-ST65</b>	×6	65mm	4.6μm	0.091mm	0.073	40.9	0.0023%	1/2"	55g	C-mount	A-3057
<b>MML6-ST65S</b>	×6	65.3mm	4.4μm	0.09mm	0.076	39.3	0.002%	1/2"	38g	C-mount	A-3108
<b>MML8-ST65S</b>	×8	64.9mm	4.4μm	0.07mm	0.076	50	-0.003%	1/2"	42g	C-mount	A-3081

\*Field depth values were calculated assuming a resolution equivalent to 1/2" CCD horizontal 240 TV display resolution (permitted circle of confusion diameter 40 μm).  
\*Resolution values are for theoretical resolution at a wavelength of 550 nm.

# WD110mm



MML-ST Series

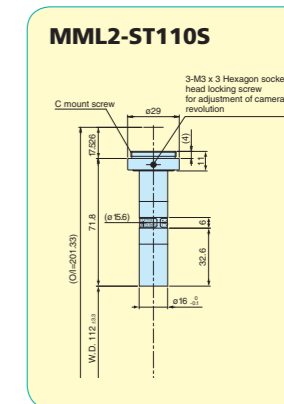
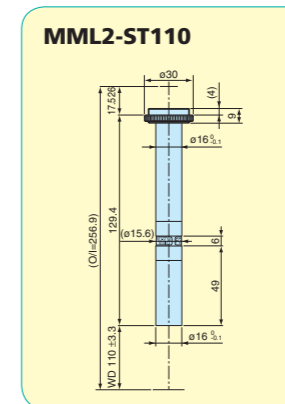
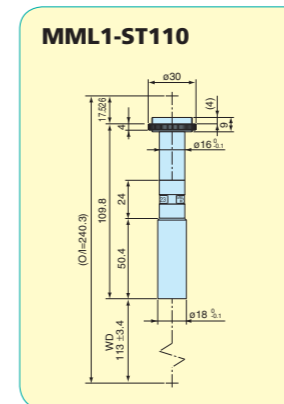
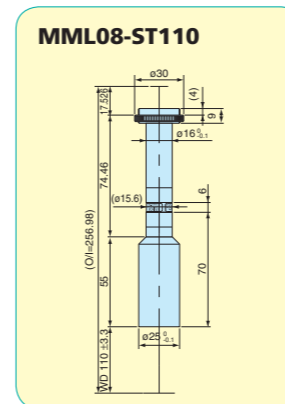
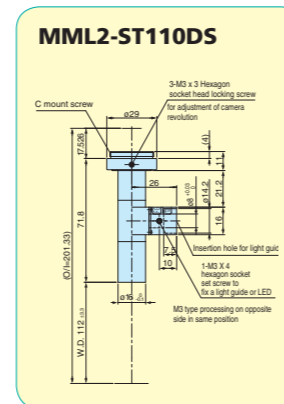
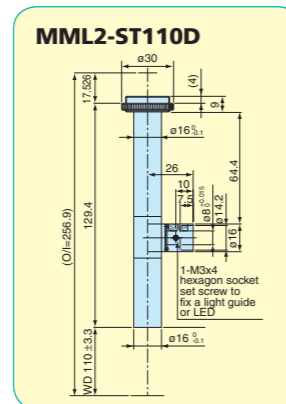
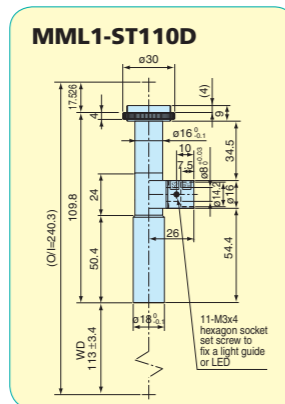
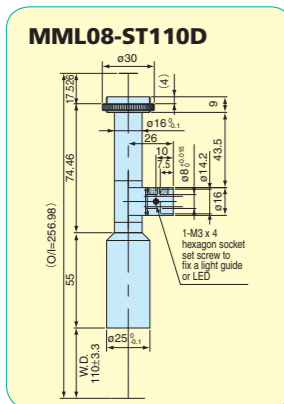

MML-ST Series

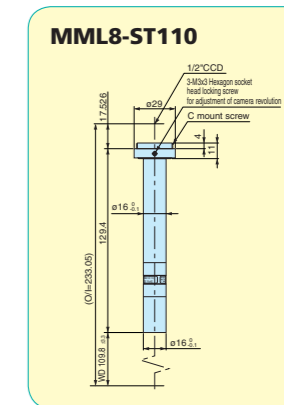
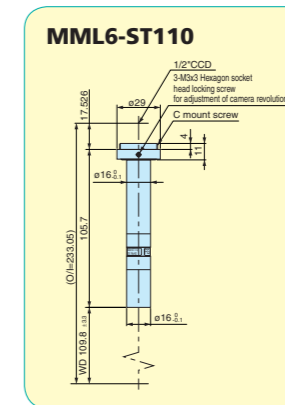
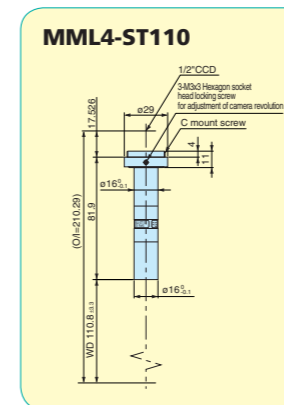
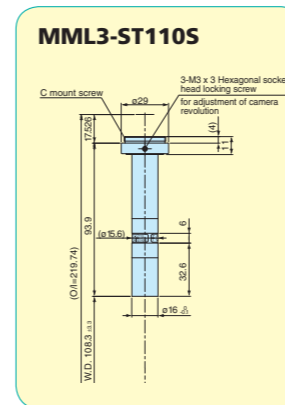
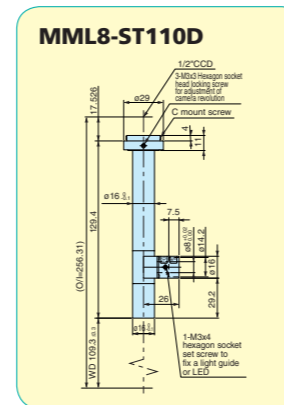
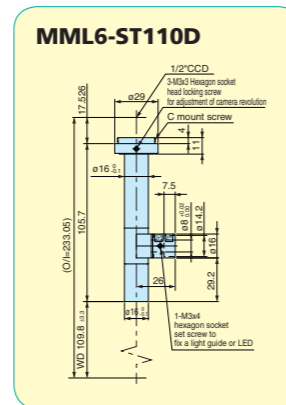
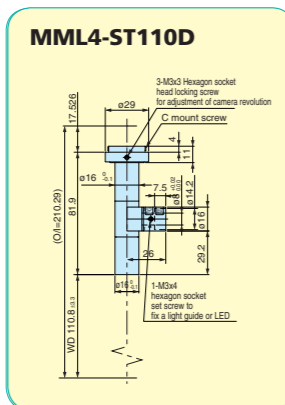
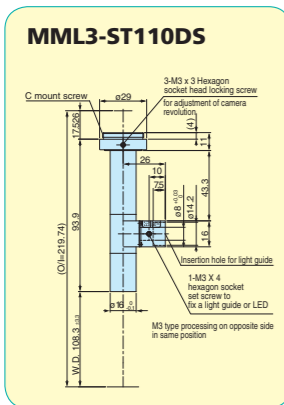

Product name	Magnification	WD	Resolution	Depth of field	NA	Effective Fno	TV distortion	Largest compatible CCD	Weight	Mount	Commodity code
MML08-ST110D	x0.8	110.0mm	13.5µm	2.00mm	0.024	16.1	0.002%	1/2"	85g	C-mount	A-3002
MML1-ST110D	x1	113.0mm	14µm	1.68mm	0.024	20.9	0.05%	1/2"	58g	C-mount	A-3003
MML2-ST110D	x2	110.0mm	11µm	0.66mm	0.03	33.2	0.006%	1/2"	55g	C-mount	A-3004
MML2-ST110DS	x2	112.0mm	11.2µm	0.66mm	0.03	33.2	0.008%	2/3"	39g	C-mount	A-3109
MML3-ST110DS	x3	108.3mm	11.2µm	0.44mm	0.03	49.7	0.008%	2/3"	43g	C-mount	A-3110
MML4-ST110D	x4	110.8mm	7µm	0.22mm	0.045	44.4	0.021%	1/2"	43g	C-mount	A-3005
MML6-ST110D	x6	109.8mm	7µm	0.17mm	0.045	66.4	-0.005%	1/2"	48g	C-mount	A-3006
MML8-ST110D	x8	109.3mm	7µm	0.17mm	0.045	88.4	-0.007%	1/2"	54g	C-mount	A-3007

Product name	Magnification	WD	Resolution	Depth of field	NA	Effective Fno	TV distortion	Largest compatible CCD	Weight	Mount	Commodity code
MML08-ST110	x0.8	110.0mm	13.5µm	2.00mm	0.024	16.1	0.002%	1/2"	78.5g	C-mount	A-3019
MML1-ST110	x1	113.0mm	14µm	1.68mm	0.024	20.9	0.05%	1/2"	50g	C-mount	A-3020
MML2-ST110	x2	110.0mm	11µm	0.66mm	0.03	33.2	0.006%	1/2"	50g	C-mount	A-3021
MML2-ST110S	x2	112.0mm	11.2µm	0.66mm	0.03	33.2	0.008%	2/3"	34g	C-mount	A-3111
MML3-ST110S	x3	108.3mm	11.2µm	0.44mm	0.03	49.7	0.008%	2/3"	37g	C-mount	A-3112
MML4-ST110	x4	110.8mm	7µm	0.22mm	0.045	44.4	0.021%	1/2"	38g	C-mount	A-3064
MML6-ST110	x6	109.8mm	7µm	0.17mm	0.045	66.4	-0.005%	1/2"	43g	C-mount	A-3065
MML8-ST110	x8	109.3mm	7µm	0.17mm	0.045	88.4	-0.007%	1/2"	49g	C-mount	A-3066

### Optical Specifications for Machine Types Recommended for Combination with the Rear Converter

Product Name	Converter	Magnification	Resolution	Depth of field	Effective Fno
MML08-ST110D/110	SOD-1.5X	1.2 X	13.5µm	1.34mm	24.2
	SOD-2X	1.6 X	13.5µm	1.00mm	32.2
MML1-ST110D/110	SOD-1.5X	1.5 X	14µm	1.11mm	31.4
	SOD-2X	2.0 X	14µm	0.84mm	41.8
MML2-ST110D/110	SOD-1.5X	3 X	11µm	0.44mm	49.8

\*Field depth values were calculated assuming a resolution equivalent to 1/2" CCD horizontal 240 TV display resolution (permitted circle of confusion diameter 40 µm).  
 \*Resolution values are for theoretical resolution at a wavelength of 550 nm.

Caution) If machines other than those recommended for combination are used, foreign objects and damage of the rear converter may be contained in the images. For this reason, do not use any machines other than the recommended types.



MML-ST Series

# Long WD Series

## WD150mm

MML-ST Series

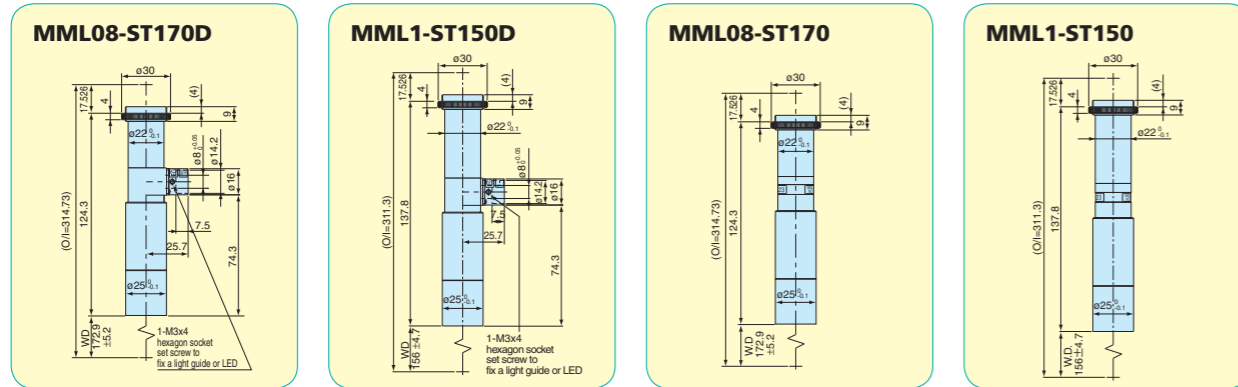

Product name	Magnification	WD	Resolution	Depth of field	NA	Effective Fno	TV distortion	Largest compatible CCD	Weight	Mount	Commodity code
<b>MML08-ST170D</b>	x0.8	172.9	12µm	1.79mm	0.028	14	0.022%	1/2"	80g	CMount	A-3008
<b>MML1-ST150D</b>	x1	156.0	8.8µm	1.05mm	0.038	13	0.021%	1/2"	90g	CMount	A-3009
<b>MML08-ST170</b>	x0.8	172.9	12µm	1.79mm	0.028	14	0.022%	1/2"	76g	CMount	A-3022
<b>MML1-ST150</b>	x1	156.0	8.8µm	1.05mm	0.038	13	0.021%	1/2"	84g	CMount	A-3023

\*Resolution values are for theoretical resolution at a wavelength of 550 nm.  
\*Field depth values were calculated assuming a resolution equivalent to 1/2" CCD horizontal 240 TV display resolution (permitted circle of confusion diameter 40 µm).

Optical Specifications for Machine Types Recommended for Combination with Rear Converter

Product name	Converter	Magnification	Resolution	Depth of field	Effective Fno
<b>MML08-ST170D/170</b>	<b>SOD-1.5X</b>	1.2X	12µm	1.17mm	21
	<b>SOD-2X</b>	1.6X	12µm	0.88mm	28
<b>MML1-ST150D/150</b>	<b>SOD-1.5X</b>	1.5X	8.8µm	0.69mm	19.5
	<b>SOD-2X</b>	2.0X	8.8µm	0.52mm	26

Caution) If machines other than those recommended for combination are used, foreign objects and damage of the rear converter may be contained in the images. For this reason, do not use any machines other than the recommended types.

## WD300mm

MML-ST Series

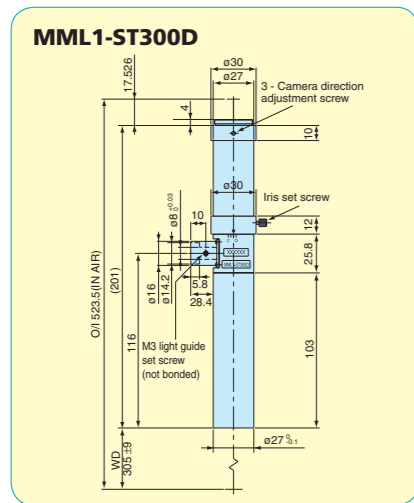

- Magnification 1x
- WD = 300 mm
- With variable aperture 22.7-C32
- External diameter 27 mm slim body

A super-long working distance lens that realizes a WD of 300 mm with an optical magnification of 1x.  
Improved ease of use with variable aperture.

Optical Specifications for Machine Types Recommended for Combination with Rear Converter

Product Name	Converter	Magnification	Resolution	Depth of field	Effective Fno
<b>MML1-ST300D</b>	<b>SOD-1.5X</b>	1.5X	15µm	1.21mm	34.1
	<b>SOD-2X</b>	2.0X	15µm	0.91mm	45.4

Note: Combine each rear converter with the recommended models only. Otherwise, dust or scratch on the rear converter may form an image.

Product name	Magnification	WD	Resolution	Depth of field	NA	Effective Fno	TV distortion	Largest compatible CCD	Weight	Mount	Commodity code
<b>MML1-ST300D</b>	x1	305mm	15µm	1.82mm	0.022	22.7-C32	0.05%	1/2"	150g	CMount	A-3061

\*Resolution indicates a theoretical resolution at a wavelength of 550nm.  
\*Depth of field is calculated assuming a horizontal 320 TV resolution using a 1/2" CCD camera. (Permissible circle of confusion on the image-formation side: 40µm)



# MML Series



MML Series

## WD110mm

MML Series

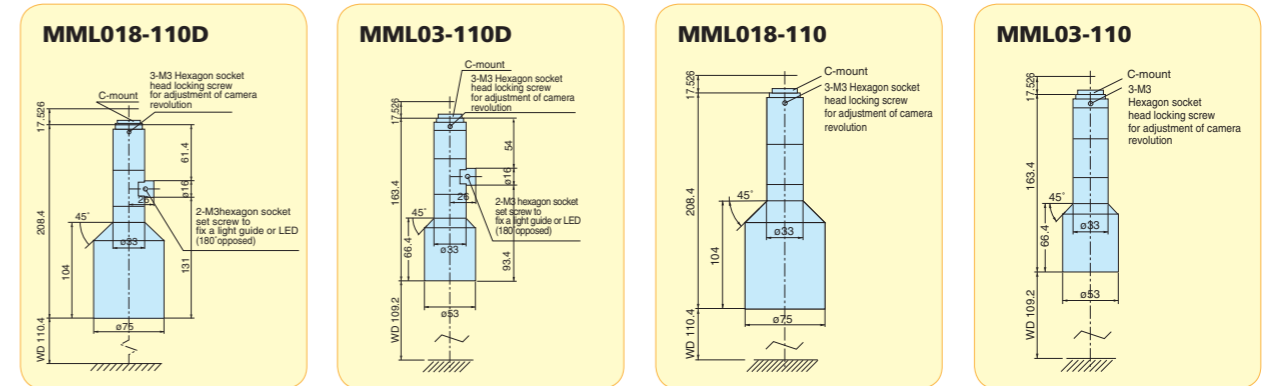

Product name	Magnification	WD	Resolution	Depth of field	NA	Effective Fno	TV distortion	Largest compatible CCD	Weight	Mount	Commodity code
<b>MML018-110D</b>	x0.18	110.4mm	24µm	15mm	0.01	6.4	0.1% or less	2/3"	700g	C-mount	A-0041
<b>MML03-110D</b>	x0.3	109.2mm	16µm	6mm	0.02	7	0.1% or less	2/3"	380g	C-mount	A-0043
<b>MML018-110</b>	x0.18	110.4mm	24µm	15mm	0.01	6.4	0.1% or less	2/3"	700g	C-mount	A-0040
<b>MML03-110</b>	x0.3	109.2mm	16µm	6mm	0.02	7	0.1% or less	2/3"	380g	C-mount	A-0042

\*Resolution values are for theoretical resolution at a wavelength of 550 nm.  
\*Field depth values were calculated assuming a resolution equivalent to 1/2" CCD horizontal 240 TV display resolution (permitted circle of confusion diameter 40 µm).

## WD195mm

MML Series

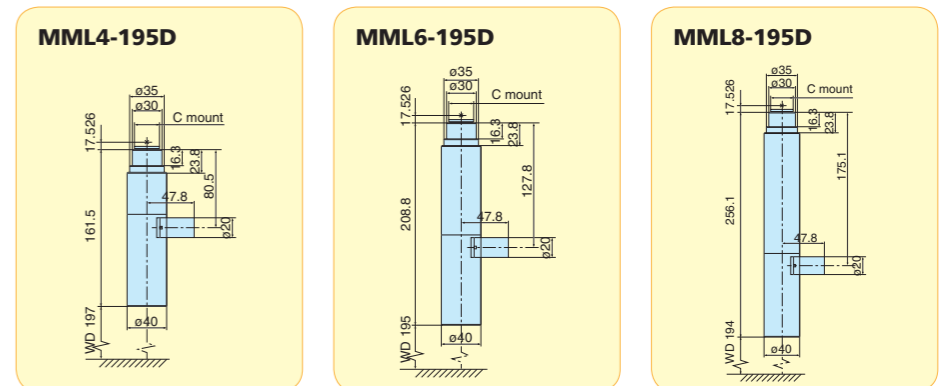

Product name	Magnification	WD	Resolution	Depth of field	NA	Effective Fno	TV distortion	Largest compatible CCD	Weight	Mount	Commodity code
<b>MML4-195D</b>	x4	197mm	4.2µm	130µm	0.08	25.3	0.1% or less	2/3"	480g	C-mount	A-0061
<b>MML6-195D</b>	x6	195mm	4.2µm	80µm	0.08	37.6	0.1% or less	2/3"	490g	C-mount	A-0062
<b>MML8-195D</b>	x8	194mm	4.2µm	60µm	0.08	49.9	0.1% or less	2/3"	500g	C-mount	A-0063

\*Resolution values are for theoretical resolution at a wavelength of 550 nm.  
\*Field depth values were calculated assuming a resolution equivalent to 1/2" CCD horizontal 240 TV display resolution (permitted circle of confusion diameter 40 µm).





# WD65mm

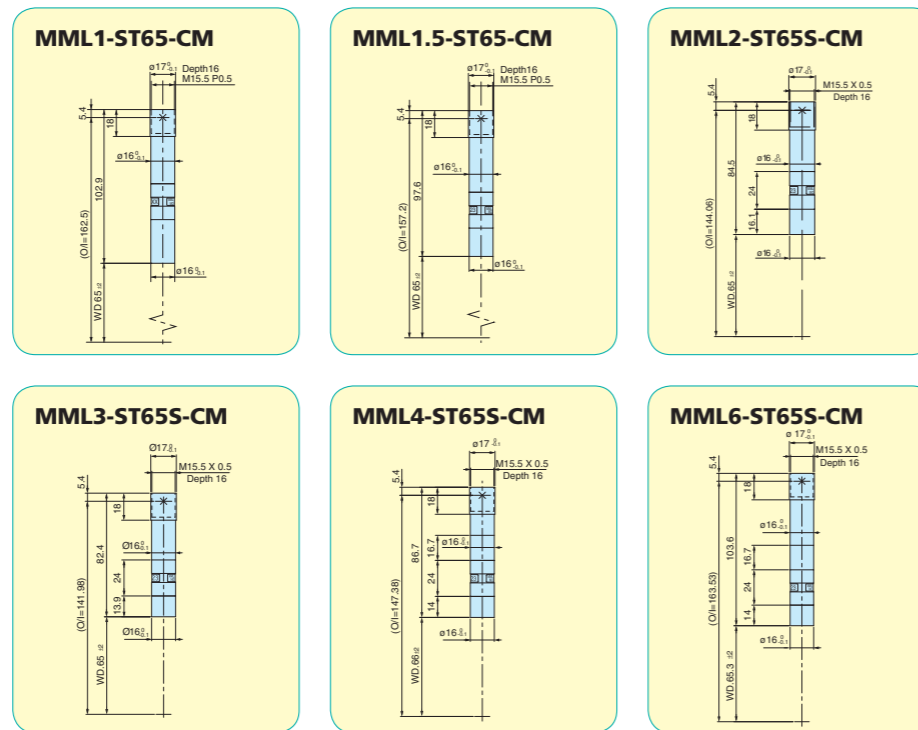

# WD110mm

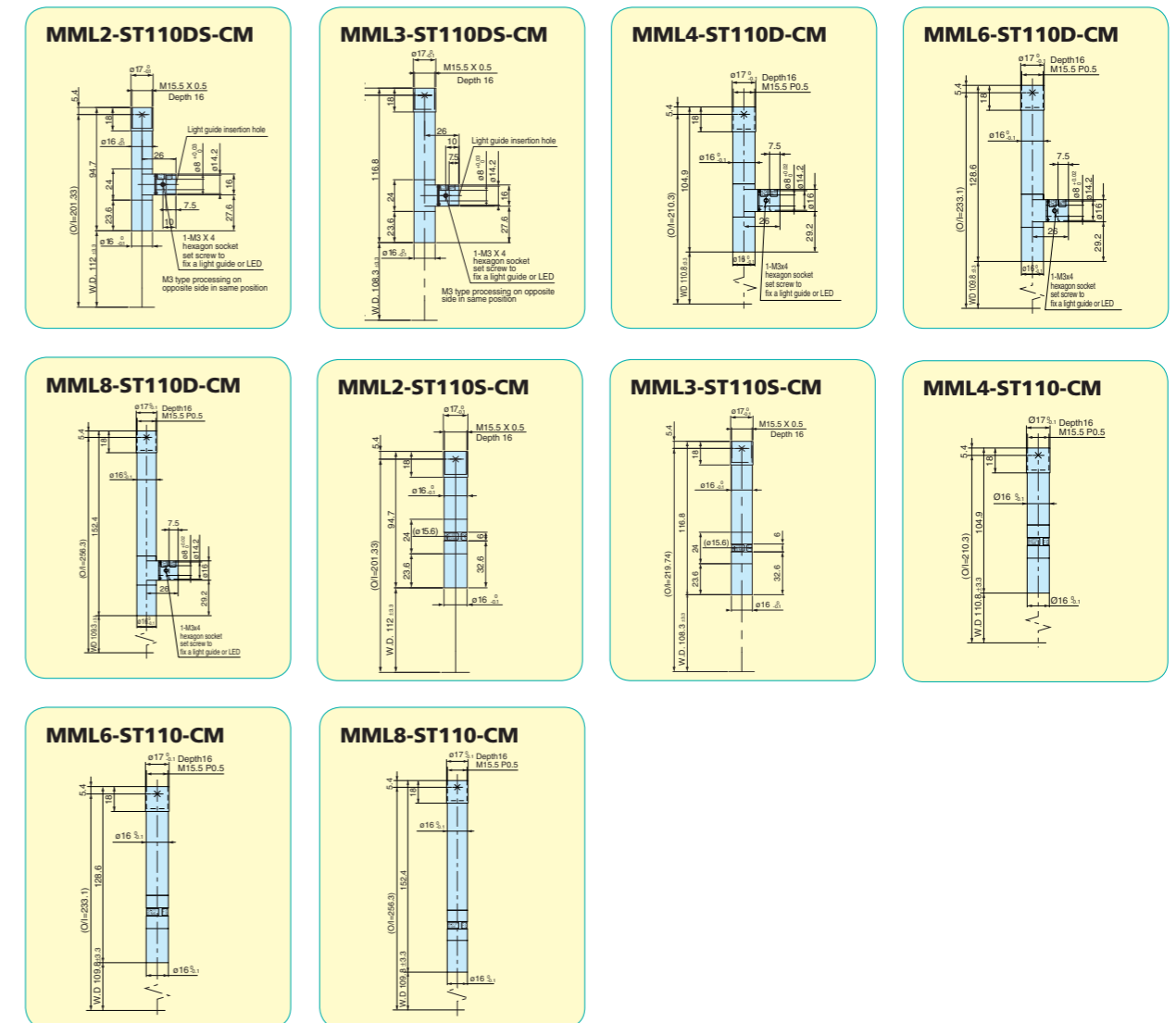

Product name	Magnification	WD	Resolution	Depth of field	NA	Effective Fno	TV distortion	Largest compatible CCD	Weight	Mount	Commodity coder
<b>MML1-ST65-CM</b>	×1	65.0mm	12.5μm	1.49mm	0.027	18.6	0.002%	1/2"	38g	M15.5 P0.5	A-3075
<b>MML1.5-ST65-CM</b>	×1.5	65.0mm	7.0μm	0.56mm	0.048	15.5	-0.036%	1/2"	36g	M15.5 P0.5	A-3076
<b>MML2-ST65S-CM</b>	×2	65.0mm	5.6μm	0.35mm	0.06	17.3	0.004%	1/2"	29g	M15.5 P0.5	A-3117
<b>MML3-ST65S-CM</b>	×3	65.0mm	4.7μm	0.19mm	0.069	21.9	0.003%	1/2"	27g	M15.5 P0.5	A-3118
<b>MML4-ST65S-CM</b>	×4	66.0mm	4.4μm	0.13mm	0.076	25.9	0.011%	1/2"	33g	M15.5 P0.5	A-3119
<b>MML6-ST65S-CM</b>	×6	65.3mm	4.4μm	0.09mm	0.076	39.3	0.002%	1/2"	35g	M15.5 P0.5	A-3120

\*Field depth values were calculated assuming a resolution equivalent to 1/2" CCD horizontal 240 TV display resolution (permitted circle of confusion diameter 40 μm).  
 \*Resolution values are for theoretical resolution at a wavelength of 550 nm.

Product name	Magnification	WD	Resolution	Depth of field	NA	Effective Fno	TV distortion	Largest compatible CCD	Weight	Mount	Commodity coder
<b>MML2-ST110DS-CM</b>	×2	112.0mm	11.2μm	0.66mm	0.030	33.2	0.008%	1/2"	36g	M15.5 P0.5	A-3121
<b>MML3-ST110DS-CM</b>	×3	108.3mm	11.2μm	0.44mm	0.030	49.7	0.008%	1/2"	40g	M15.5 P0.5	A-3122
<b>MML4-ST110D-CM</b>	×4	110.8mm	7.5μm	0.22mm	0.045	44.4	0.021%	1/2"	40g	M15.5 P0.5	A-3067
<b>MML6-ST110D-CM</b>	×6	109.8mm	7.5μm	0.17mm	0.045	66.4	-0.005%	1/2"	45g	M15.5 P0.5	A-3068
<b>MML8-ST110D-CM</b>	×8	109.3mm	7.5μm	0.17mm	0.045	88.4	-0.007%	1/2"	51g	M15.5 P0.5	A-3069
<b>MML2-ST110S-CM</b>	×2	112.0mm	11.2μm	0.66mm	0.030	33.2	0.008%	1/2"	31g	M15.5 P0.5	A-3123
<b>MML3-ST110S-CM</b>	×3	108.3mm	11.2μm	0.44mm	0.030	49.7	0.008%	1/2"	34g	M15.5 P0.5	A-3124
<b>MML4-ST110-CM*</b>	×4	110.8mm	7.5μm	0.22mm	0.045	44.4	0.021%	1/2"	35g	M15.5 P0.5	A-3070
<b>MML6-ST110-CM*</b>	×6	109.8mm	7.5μm	0.17mm	0.045	66.4	-0.005%	1/2"	40g	M15.5 P0.5	A-3071
<b>MML8-ST110-CM*</b>	×8	109.3mm	7.5μm	0.17mm	0.045	88.4	-0.007%	1/2"	46g	M15.5 P0.5	A-3072

\* Made-to-Order

\*Field depth values were calculated assuming a resolution equivalent to 1/2" CCD horizontal 240 TV display resolution (permitted circle of confusion diameter 40 μm). However, design values from resolution are used for \*1.  
 \*Resolution values are for theoretical resolution at a wavelength of 550 nm.



for Compact camera (12 mm dia.)

MML-CS1 Series

MML-CS1 Series models are thin, space-saving, and lightweight so they can be mounted on micro-head cameras.

MML-CS1 Series models are mounted on 12mm(M10.5 p0.5).



for Near-infrared Camera (770 to 1200 nm)

MML-NIR Series

The MML-NIR Series is designed for the wavelength band from 770 to 1200 nm.

This series provides special MML-use lenses that allow the observation of in-wafer defects and rear patterns if combined with an infrared camera and illumination.



WD65mm

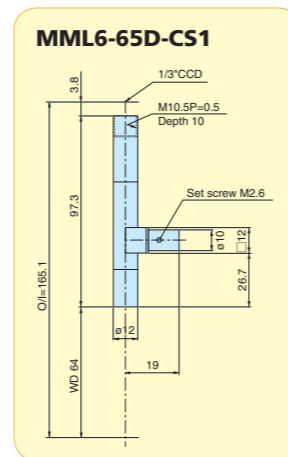
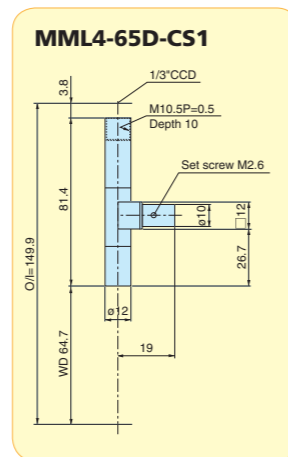
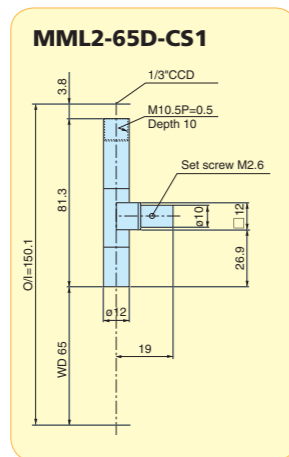

	MML4-80D-IR	MML6-80D-IR	MML8-80D-IR
D-IRMagnification	4 X	6 X	8 X
WD	82.4mm	81.5mm	81mm
Resolution		4.0μm	
Depth of field	50μm	33μm	27μm
NA		0.15	
Effective Fno	13.3	20.1	26.9
TV distortion	0.01% or less		
Largest compatible CCD	2/3"		
Weight	90g	100g	110g
Mount	C-mount		
Commodity code	A-0235	A-0236	A-0237

\*Depth of field is calculated assuming a horizontal 565 TV resolution using a 2/3" CCD camera. (Permissible circle of confusion on the image-formation side: 30μm)  
 \*Resolution indicates a theoretical resolution at a wavelength of 985nm.

Spectral characteristics

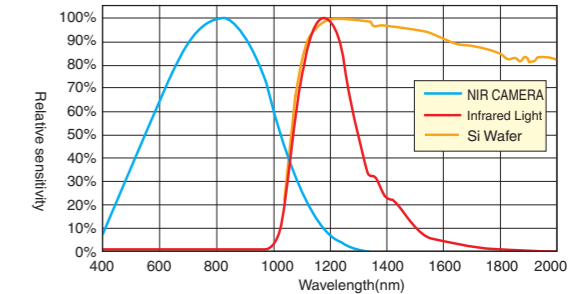

WD110mm

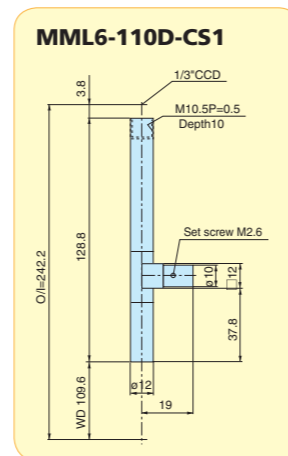
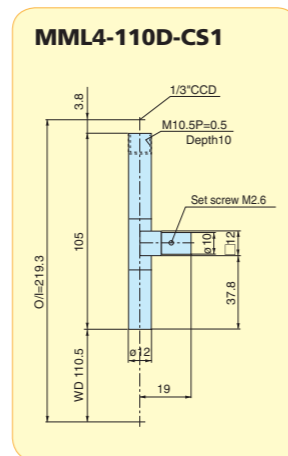
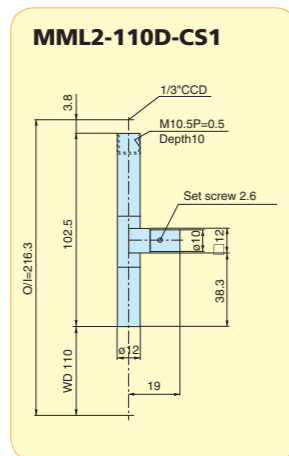

Product name	Magnification	WD	Resolution	Depth of field	NA	TV distortion	TV distortion	Largest compatible CCD	Weight	Mount	Commodity code
MML2-65D-CS1	x 2	65mm	5.8μm	260μm	0.06	17.4	0.1% or less	1/3"	45g	M10.5 P0.5	A-0098
MML4-65D-CS1	x 4	64.7mm	5μm	110μm	0.07	29.8	0.2% or less	1/3"	47g	M10.5 P0.5	A-0099
MML6-65D-CS1	x 6	64mm	5μm	74μm	0.07	44.2	0.1% or less	1/3"	50g	M10.5 P0.5	A-0100
MML2-110D-CS1	x 2	110mm	11μm	500μm	0.03	33.2	0.1% or less	1/3"	60g	M10.5 P0.5	A-0101
MML4-110D-CS1	x 4	110.5mm	8.6μm	220μm <sup>†1</sup>	0.04	51.1	0.1% or less	1/3"	60g	M10.5 P0.5	A-0102
MML6-110D-CS1	x 6	109.6mm	8.5μm	220μm <sup>†1</sup>	0.04	76.3	0.1% or less	1/3"	63g	M10.5 P0.5	A-0103

<sup>†1</sup>Depth of field is calculated assuming a horizontal 320 TV resolution using a 1/3" CCD camera. (Permissible circle of confusion on the image-formation side: 30μm) But 1 is calculated based on resolution.  
 \*Resolution indicates a theoretical resolution at a wavelength of 550nm.

Example application

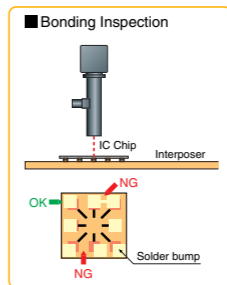
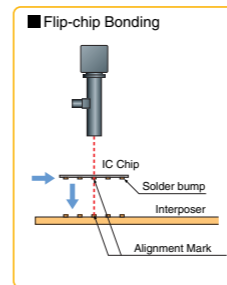
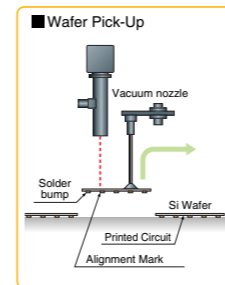

Infrared coaxial transmission observation

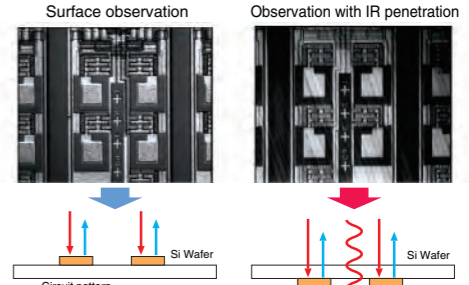

Consumables and Related Products



● Infrared halogen light source

Model	MHAB-100W-IR
Specification	Emission of 1100nm or more
Commodity code	A-0524



● Spare Lamp

Model	LM-100-IR
Specification	IR reflection coating For 100W
Commodity code	A-8216

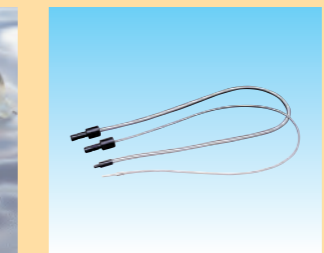

● Heat resistant light guide (HR Type)

Model	MSG4-1100S-HR
Specification	Heat Resistant specification light guide
Commodity code	A-0637



● Camera for infrared light (IR Camera)

Model	MC-781P-0030
Specification	2/3" 780Hx488pix NIR sensitivity
Commodity code	A-0346

# Prism Adaptor

## Prism Adapter

These prism adapters are for the MML-ST Series. Prism adapters make it possible to bend the optical axis at a right angle of 90 degrees, and to perform mark recognition for microscopic work by modifying the pitch between 2 MML lenses to a fine pitch.

Caution) Combination of prisms with the MML-HR Series may result in marked deterioration of the image due to individual difference of products. For this reason, the combination is not recommended.

OPTION  
Option

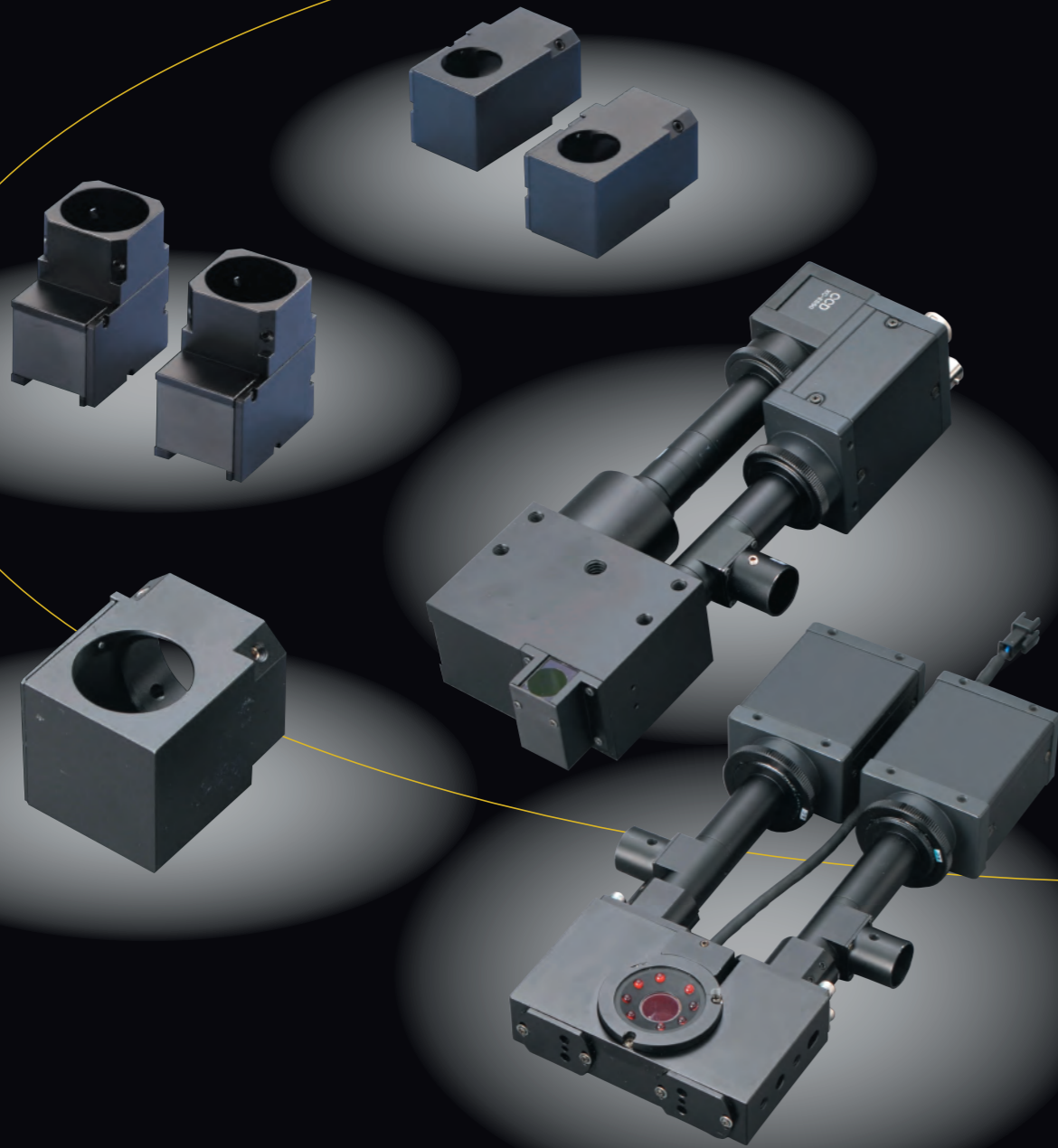

### 90° Side Vision Right Angle Mirror Type MML-PL16 MML-PL18 MML-PL25

The optical axis can be bent at a 90° right angle. This is useful when there is no space in the upper direction.  
The monitor image becomes the mirror image.

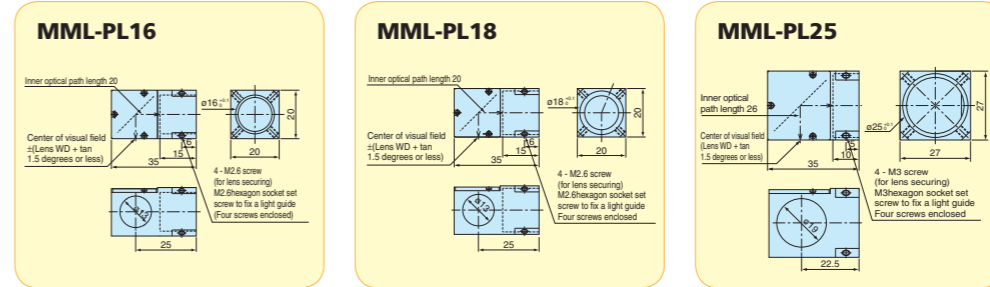
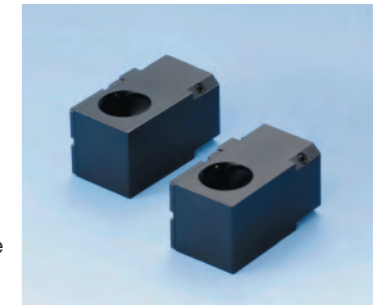

Model	MML-PL16	MML-PL18	MML-PL25	MML-GA20
Specification	For 16 dia. lens	For 18 dia. lens	For 25 dia. lens	Cover glassø20 t=1mm
Inner optical path length	20mm	20mm	26mm	
Commodity code	A-8004	A-8005	A-8006	A-8062

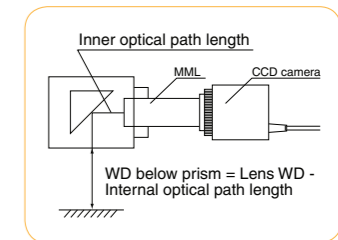

### MML-P1 MML-P3 MML-P4

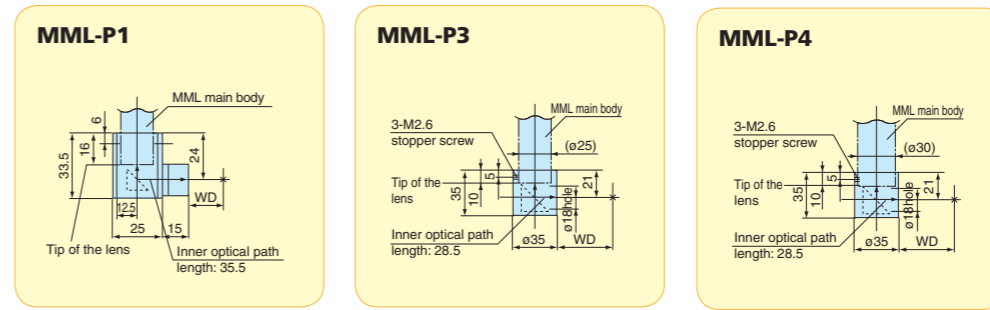
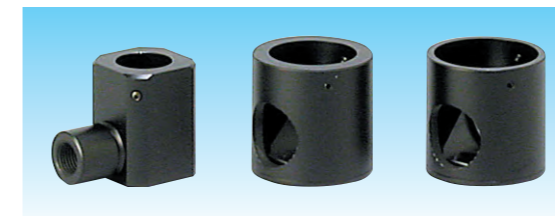

Model	MML-P1	MML-P3	MML-P4
Commodity code	A-8001	A-8002	A-8003

\*Working distance in the drawings are that of the lenses, inner optical path length

OPTION  
Options

### 90° Side Vision Pentaprism Type MML-P5 MML-P6 MML-P8

Images are shown erect and upright by the pentaprism.

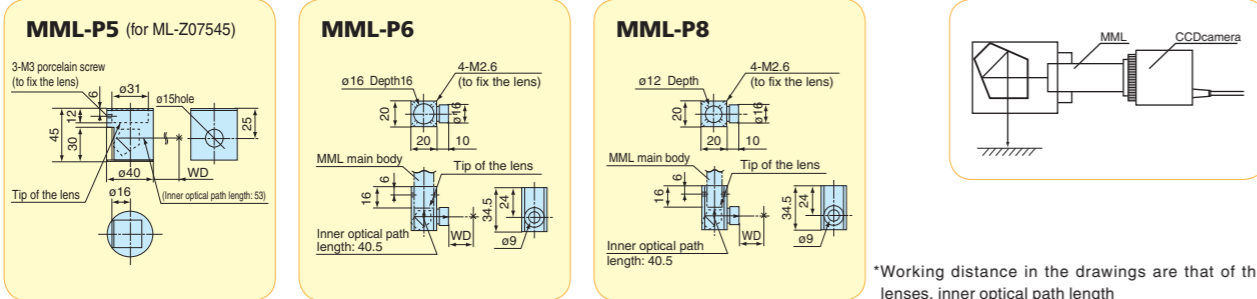
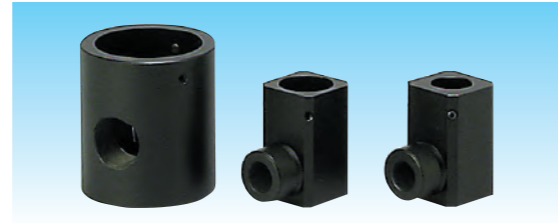

\*Working distance in the drawings are that of the lenses, inner optical path length

Model	MML-P5	MML-P6	MML-P8
Commodity code	A-8009	A-8010	A-8011

### Optical Axis Pitch Variable Type (Pitch 3 mm type) MML-PP16 MML-PP18 MML-PP25

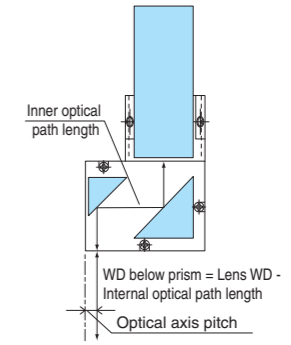
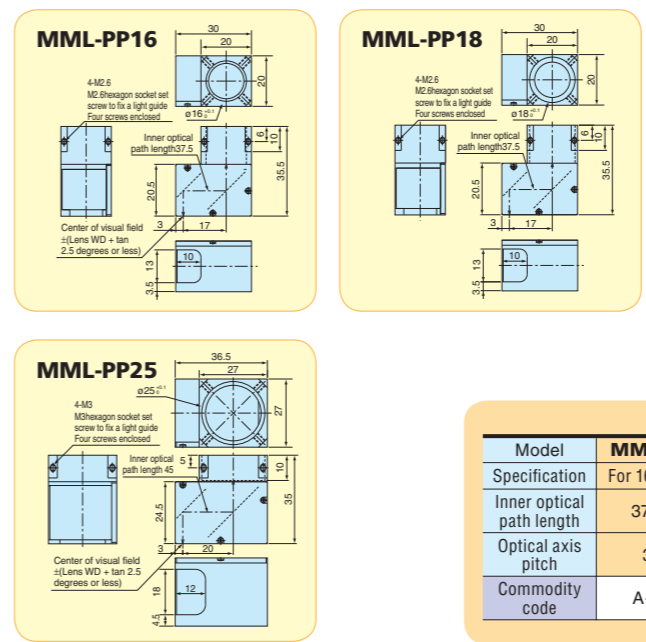

Model	MML-PP16	MML-PP18	MML-PP25	MML-GA1411	MML-GA1913
Specification	For 16 dia. lens	For 18 dia. lens	For 25 dia. lens	Cover glass 14 x 11 t=1mm	Cover glass 19 x 13 t=1mm
Inner optical path length	37.5mm	37.5mm	35mm		
Optical axis pitch	3mm	3mm	3mm	A-8063	A-8064
Commodity code	A-8020	A-8021	A-8022		

### Optical Axis Variable Type MML-P2 MML-P7 MML-P9

Mark recognition is possible for fine pitch between 2 points of extremely small work.

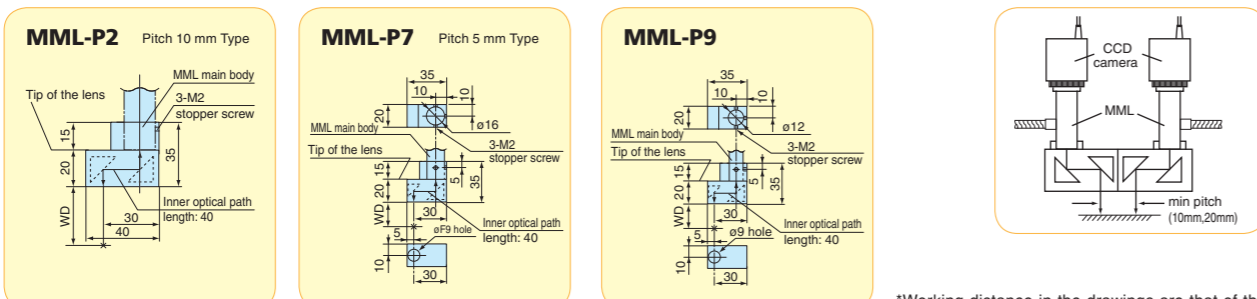
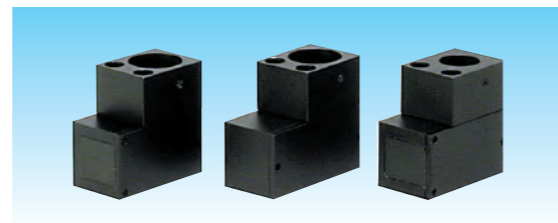

\*Working distance in the drawings are that of the lenses, inner optical path length

Model	MML-P2	MML-P7	MML-P9
Commodity Code	A-8017	A-8018	A-8019

### Optical Axis Variable Prism MML-PP Series Field of Vision Vignetting Chart

Because of narrow-pitch design, the MML-PP Series is subject to vignetting. Since vignetting varies with the customer environment, such as object being inspected and illumination, be sure to test the prism in the actual setup.  
 \*This value is calculated but not guaranteed. Use the value for reference only.

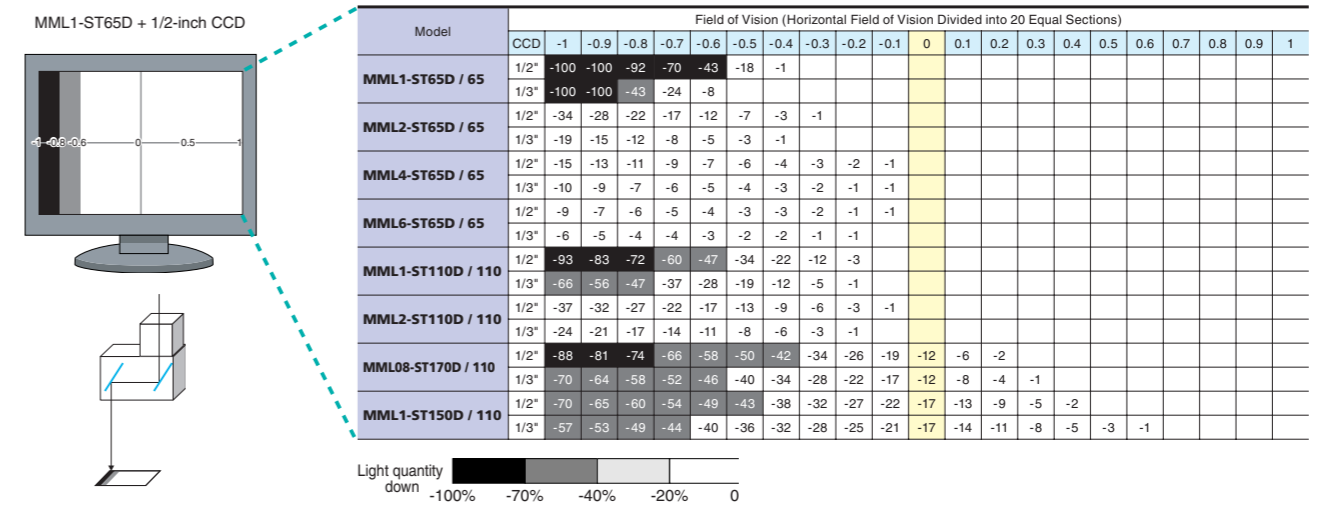





High-performance low magnification zoom lens  
Manual type

# ML-Z0220D

Electric motorized type

# ML-Z0220DM



- Magnification range: 0.2X to 2X (zoom ratio of 10:1)
- WD=173mm
- Includes integrated coaxial episcopic illuminationsystem that covers the entire view.
- A special light is attached.

Coaxial light guide (super random specification) L=800mm  
Color filters (red, green) are attached.

ML-Z0220D

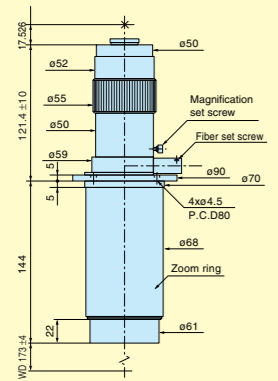

ML-Z0220DM

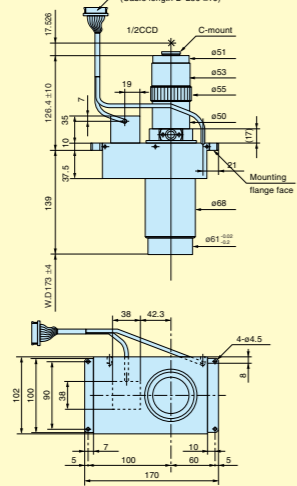

ML-Z0220DM Wiring arrangement

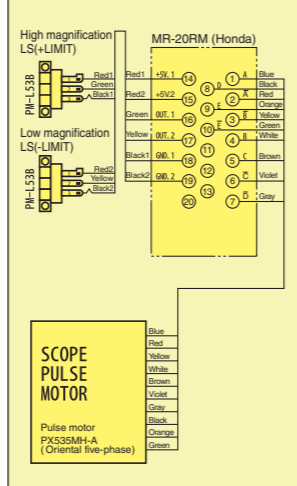

\*Contact us if you need a motor drive or controller.

Model	ML-Z0220D	ML-Z0220DM
Magnification	0.2X to 2X (zoom ratio of 10:1)	
WD	173±4	
Zoom click position	at 0.2X	at 1X    at 2X
Effective Fno	3.6	11.5    20
Depth of field	7mm	0.9mm    0.4mm
Resolution	12µm	7.8µm    7µm
TV distortion	0.03% or less	0.15% or less    0.13% or less
NA	0.03	0.04    0.05
Largest compatible CCD	1/2"	
Weight	1100g	1900g
Mount	C-mount	
Commodity code	A-0110	A-0111

\*Depth of field is calculated assuming a horizontal 320 TV resolution using a 1/2" CCD camera. (Permissible circle of confusion on the image-formation side: 40µm)  
\*Resolution indicates a theoretical resolution at a wavelength of 550nm.

Manual click zoom lens  
**ML-Z0315D**



- Magnification range: 0.3X to 1.5X (click one of five levels)
- WD=151.2mm
- Integrated coaxial episcopic illumination system that covers the entire view.

A manual click system allows for ±0.5% magnification repeatability.  
Magnification can be adjusted between five different levels.

Model	ML-Z0315D				
Magnification	0.3X to 1.5X (zoom ratio of 5:1)				
WD	151.2±7.6				
Zoom click position	x 0.3	x 0.6	x 0.8	x 1.2	x 1.5
Effective Fno	9.3	11.1	12.4	14.7	16.5
Depth of field	8.2mm	2.4mm	1.5mm	0.8mm	0.6mm
Resolution	20.8µm	12.4µm	10.4µm	8.2µm	7.4µm
TV distortion	-0.09%	-0.05%	-0.02%	0.03%	0.06%
NA	0.02	0.03	0.03	0.04	0.05
Largest compatible CCD	1/2"				
Weight	About 520g				
Mount	C-mount				
Commodity code	A-0112				

\*Depth of field is calculated assuming a horizontal 320 TV resolution using a 1/2" CCD camera. (Permissible circle of confusion on the image-formation side: 40µm)  
\*Resolution indicates a theoretical resolution at a wavelength of 550nm.

ML-Z0315D

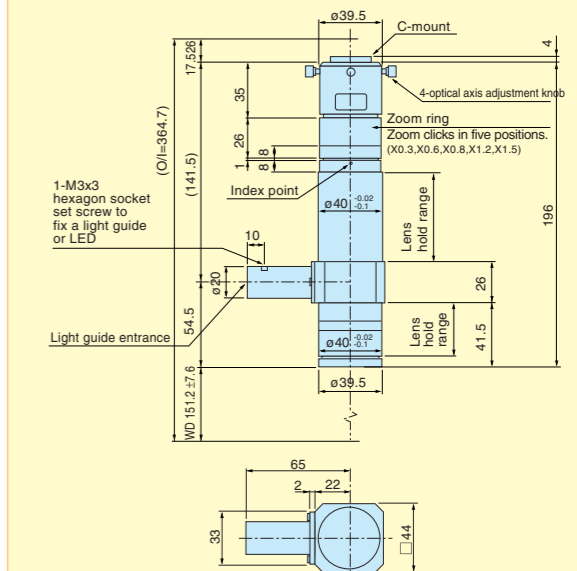

# Zoom Lens ML-Z07545 Series



- Magnification x0.75 to x4.5 (zoom comparison 6x)
- WD = 90 mm
- With uniform coaxial incident illumination function that covers the entire field of vision.
- Internal focus adjustment function (WD can be adjusted to -6 mm)

A standard model zoom lens with outstanding functionality. Adjustment of magnification and WD is possible through combination with options.

### Manual zoom

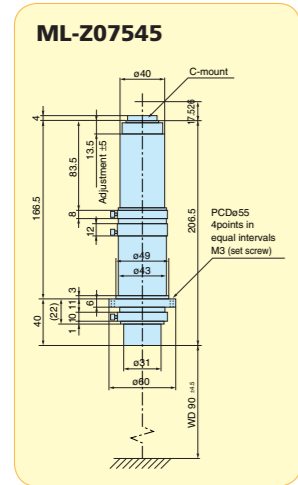

### Coaxial incident zoom

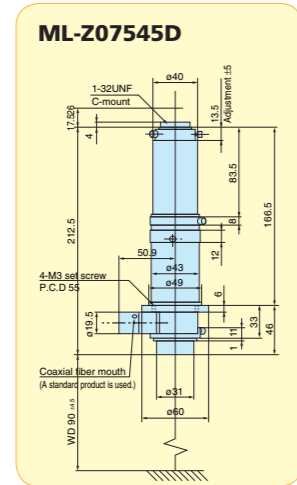

### Coaxial incident zoom with deflection function

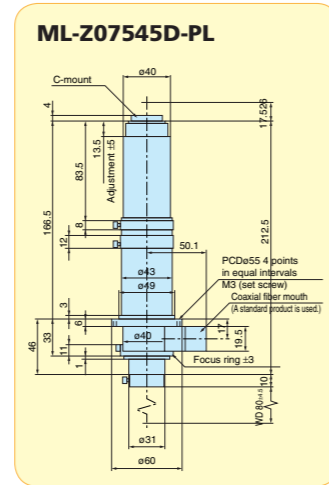

### Motor Zoom

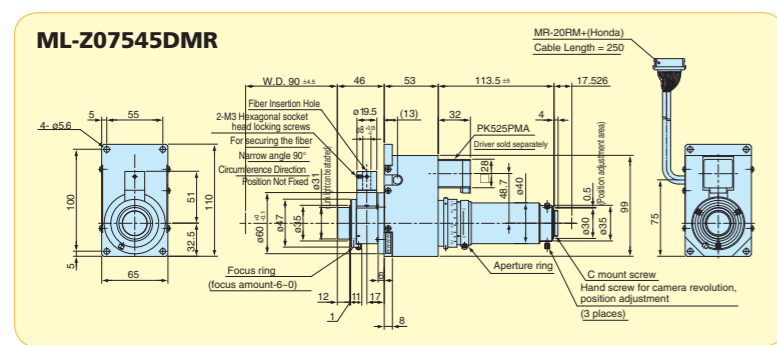

### Model explanation

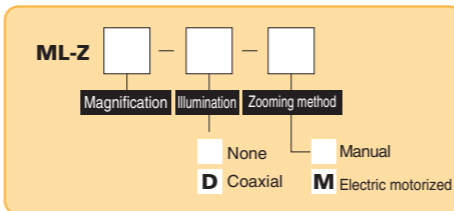

• All models equipped with focus, aperture, and zoom.

Model	ML-Z07545	ML-Z07545D	ML-Z07545D-PL	ML-Z07545DMR
Magnification	x0.75 to x 4.5 (zoom comparison 6x)			
WD (mm)	90±4.5			
Focus amount	0 ~ -6mm			
With/Without motor	Without (manual zoom)			With (motorized zoom/pulse control)
Zoom position	x0.75 time	x2 time	x4.5 time	
Effective Fno	11	16	28	
Field depth	1.6mm	0.3mm	0.1mm	
Resolution	9.9µm	5.4µm	4.2µm	
TV distortion	0.02% or less	0.01% or less	-0.02% or less	
NA	0.03	0.06	0.08	
Operation function	All models equipped with focus, aperture, and zoom.			
Weight	Approx. 440 g	Approx. 470 g	Approx. 490 g	Approx 1000 g
Largest Compatible CCD	1/2"			
Mount	C mount			
Commodity code	A-0118	A-0119	A-0120	A-0122

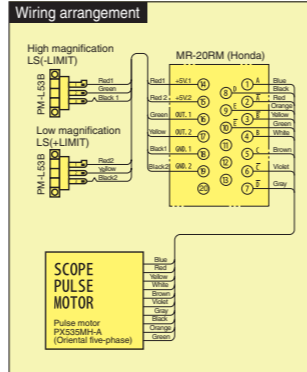

## Options

Sold separately

### Proxar lens

## ML-Z Series



Attach on the tip of a lens to change magnification and working distance.

Model	Focus position	ML-Z07545			ML-Z07545D/DM		
		Magnification. Min-Max	WD	Matching	Magnification. Min-Max	WD	Matching
ML-Z03	Near	x 0.24 ~ x 1.43	255mm	○	x 0.23 ~ x 1.4	263mm	▲
	Middle	x 0.23 ~ x 1.36	283mm		x 0.22 ~ x 1.33	292mm	
	Far	x 0.21 ~ x 1.28	315mm		x 0.21 ~ x 1.25	325mm	
ML-Z04	Near	x 0.31 ~ x 1.87	195mm	○	x 0.31 ~ x 1.84	200mm	▲
	Middle	x 0.3 ~ x 1.81	211mm		x 0.3 ~ x 1.81	216mm	
	Far	x 0.29 ~ x 1.72	229mm		x 0.29 ~ x 1.72	234mm	
ML-Z05	Near	x 0.38 ~ x 2.27	160mm	○	x 0.37 ~ x 2.25	163mm	▲
	Middle	x 0.37 ~ x 2.24	170mm		x 0.37 ~ x 2.21	174mm	
	Far	x 0.36 ~ x 2.2	181mm		x 0.36 ~ x 2.17	185mm	
ML-Z07	Near	x 0.52 ~ x 3.17	114mm	○	x 0.52 ~ x 3.16	115mm	▲
	Middle	x 0.53 ~ x 3.16	119mm		x 0.52 ~ x 3.16	121mm	
	Far	x 0.53 ~ x 3.17	125mm		x 0.52 ~ x 3.16	126mm	
ML-Z14	Near	x 1.03 ~ x 6.21	53.4mm	○	x 1.03 ~ x 6.21	53.8mm	○
	Middle	x 1.05 ~ x 6.33	54.7mm		x 1.06 ~ x 6.37	55.1mm	
	Far	x 1.08 ~ x 6.49	56.1mm		x 1.08 ~ x 6.49	56.5mm	
ML-Z20	Near	x 1.45 ~ x 8.77	32.1mm	○	x 1.46 ~ x 8.77	32.3mm	○
	Middle	x 1.49 ~ x 9.01	32.7mm		x 1.5 ~ x 9.09	32.9mm	
	Far	x 1.54 ~ x 9.26	33.4mm		x 1.54 ~ x 9.35	33.6mm	

\*Magnification and working distance can be slightly changed by turning the focus adjuster ring (N→F). Indicated values are based on calculation formulas. Actual measurement may be different because of tolerance. They cannot be mounted on ML-Z07545D-PL.

Model	Commodity code
ML-Z03	A-8025
ML-Z04	A-8026
ML-Z05	A-8027
ML-Z07	A-8028
ML-Z14	A-8029
ML-Z20	A-8030

### Rear converter lens

## ML-Z2X

A specially designed 2X rear converter. Mounting this between a lens and CCD camera can double the magnification without changing working distance.

\*May decrease the resolution.



Model	Commodity code
ML-Z2X	A-8036

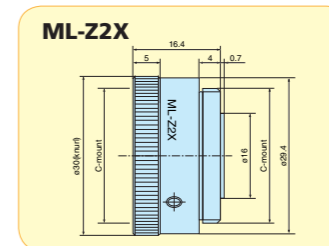

### Prism Adapter

## MML-P5

90°side-looking pent prism type

Monitored image is an electing image because of pent prism.



Model	Commodity code
MML-P5	A-8009

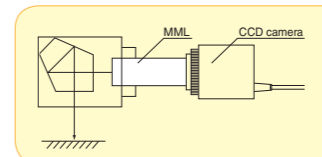

\*Field depth values were calculated assuming a resolution equivalent to 1/2" CCD horizontal 240 TV display resolution (permitted circle of confusion diameter 40 µm).  
\*Resolution values are for theoretical resolution at a wavelength of 550 nm.  
\*The value for valid Fno is for when aperture is open.



# Zoom Lens (NAVITAR) x12 Zoom Lens

Navitar's x12 zoom lens is the next-generation video zoom lens that has realized wide-view observation in a wide zooming range with excellent resolving power. This lens exhibits its power in inspecting various kinds of work, such as semiconductor wafer, board, and BGA.

### • Wide zooming range and great resolving power

The basic magnification is x0.58 to x7. By changing the combination of adapter tubing and attachment, x0.1 (resolution: 36 um) to x28 (resolution: 1 um) can be supported.

### • F(lexible design)

This lens has module-based design with priority to optical quality and mounting on equipment. By combining the zoom lens with an adapter or attachment part, the optimum magnification and WD can be selected or modified easily.

#### ■ Motor options

The motor options can control zooming and focusing efficiently by a motor. The DC motor type has an anti-slip mechanism (made of metal) to prevent damage. The stepping motor type shows excellent performance in automated applications because of accurate pitch movement.

- With 12 VDC motor magnetic encoder
- With no 12 VDC motor magnetic encoder
- Stepping motor

#### ● Limit switch

\*Contact Moritex for each product number.

#### ■ Click option [D]

Seven click points can be set for zooming: x1, x2, x3, x4, x5, x6, and x7 (basic magnification: x0.58~7). The magnification reproducibility is within 5%.

\*Append D to the end of a zoom product number for ordering.



### ● Combinations

Since the x12 zoom lens made by Navitar has a module-based design, the parts from (1) to (4) are combined to create a lens system.



Product No.	
<b>1. Mount</b>	
1-6010	C mount adapter
<b>2. Adapter tube</b>	
1-61001	x0.67 mini-adapter
1-61400	x1 mini-adapter
1-62136	x2 mini-adapter
1-6245	x1 short adapter
1-6233	x2 short adapter
<b>3. Zoom</b>	
1-50486	x12 zoom with 12 mm fine focus
1-50487-M	x12 coaxial zoom with 3 mm fine focus
<b>4. Attachment</b>	
1-50011*	x0.25 lens attachment
1-50012*	x0.5 lens attachment
1-50013*	x0.75 lens attachment
1-50014	x1.5 lens attachment
1-50015	x2 lens attachment

\*For 1-50486 only

View of field data for x12 zoom

	W.D.	Camera	Adapter tube				Resolution Low to high mag.	Depth of field Low to high mag.			
			0.67x *	1-61001	1x	1-61400/6245			2x	1-62136/6233	
Attachment	0.25x 1-50011 *	341mm	Magnification	0.1x	~ 1.2x	0.15x	~ 1.75x	0.29x	~ 3.5x	72-14	20.00-0.8
			1/3"	36.0x48.0	~ 3.0x4.0	24.0x32.0	~ 2.1x2.7	12.4x16.6	~ 1.0x1.4		
			1/2"	48.0x64.0	~ 4.0x5.3	32.0x42.7	~ 2.7x3.7	16.6x22.1	~ 1.4x1.8		
			2/3"	66.0x88.0	~ 5.5x7.3	44.0x58.7	~ 3.8x5.0	22.8x30.3	~ 1.9x2.5		
	0.5x 1-50012 *	165mm	Magnification	0.2x	~ 2.4x	0.29x	~ 3.5x	0.58x	~ 7x	36-6	6.17-0.19
			1/3"	18.0x24.0	~ 1.5x2.0	12.4x16.6	~ 1.0x1.4	6.2x8.3	~ 0.5x0.7		
			1/2"	24.0x32.0	~ 2.0x2.7	16.6x22.1	~ 1.4x1.8	8.3x11.0	~ 0.7x0.9		
			2/3"	33.0x44.0	~ 2.8x3.7	22.8x30.3	~ 1.9x2.5	11.4x15.2	~ 0.9x1.3		
	0.75x 1-50013 *	108mm	Magnification	0.29x	~ 3.5x	0.44x	~ 5.3x	0.87x	~ 10.5x	24-4	2.55-0.09
			1/3"	12.4x16.6	~ 1.0x1.4	8.2x10.9	~ 0.7x0.9	4.1x5.5	~ 0.34x0.46		
			1/2"	16.6x22.1	~ 1.4x1.8	10.9x14.5	~ 0.9x1.2	5.5x7.4	~ 0.46x0.61		
			2/3"	22.8x30.3	~ 1.9x2.5	15.0x20.0	~ 1.2x1.7	7.6x10.1	~ 0.63x0.84		
none	86mm	Magnification	0.39x	~ 4.7x	0.58x	~ 7x	1.16x	~ 14x	18-4	1.39-0.05	
		1/3"	9.2x12.3	~ 0.8x1.0	6.2x8.3	~ 0.5x0.7	3.1x4.1	~ 0.26x0.34			
		1/2"	12.3x16.4	~ 1.0x1.4	8.3x11.0	~ 0.7x0.9	4.1x5.5	~ 0.34x0.46			
		2/3"	16.9x22.6	~ 1.4x1.9	11.4x15.2	~ 0.9x1.3	5.7x7.6	~ 0.47x0.63			
1.5x 1-50014	50mm	Magnification	0.58x	~ 7x	0.87x	~ 10.5x	1.74x	~ 21x	12-2	0.64-0.02	
		1/3"	6.2x8.3	~ 0.5x0.7	4.1x5.5	~ 0.34x0.46	2.1x2.8	~ 0.17x0.23			
		1/2"	8.3x11.0	~ 0.7x0.9	5.5x7.4	~ 0.46x0.61	2.8x3.7	~ 0.23x0.30			
		2/3"	11.4x15.2	~ 0.9x1.3	7.6x10.1	~ 0.63x0.84	3.8x5.1	~ 0.31x0.42			
2.0x 1-51473	32mm	Magnification	0.78x	~ 9.4x	1.16x	~ 14x	2.32x	~ 28x	10-2	0.35-0.01	
		1/3"	4.6x6.2	~ 0.38x0.51	3.1x4.1	~ 0.26x0.34	1.6x2.1	~ 0.13x0.17			
		1/2"	6.2x8.2	~ 0.51x0.68	5.7x5.5	~ 0.34x0.46	2.1x2.8	~ 0.17x0.23			
		2/3"	8.5x11.3	~ 0.70x0.94	4.1x7.6	~ 0.47x0.63	2.8x3.8	~ 0.24x0.31			

\*Note that coaxial epi-illumination cannot cover the total field of view with a low-magnification adapter attachment.

## Optional Lens with Motorized Specifications

- Support is possible for 12x or 12x ultra zoom.
- Select from three types of standard motors.
- Manual and motorized focus is available.
- Available with or without coaxial illumination.



### • Attachment metal fixture for 12x motorized zoom Product number: 1-51272

Attachment metal fixture for 12x and 12x ultra motorized zoom

### • Controller

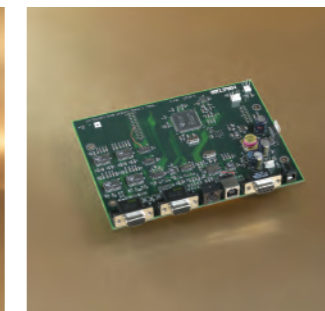

### About the Control System

Navitar has prepared a driver integrated controller that supports all types of machines with 12x motorized zoom. The control system can control one or two axes using a serial RS-232 or USB. The software contains LabView™ and Windows Graphical User Interface "GUI" for simple axis control. Connection is performed using two D sub-connectors.

### System Requirement

- Windows 98, ME, NT, 2000 or XP

### Computer Requirements

- Windows OS
- Port: 1 serial or 1 USB port (hub is possible)
- Hard Disk: 1M byte
- RAM: Same as OS

### List of Part Numbers for Motor Zoom

1 The base is a lens with motor zoom function	2 Additional functions	3 Type of motor		
		2 phase stepping	5 phase stepping	DC servo (with encoder)
12x motor zoom	12 mm motorized focus	1-51188	1-51206	1-51190
	3 mm motorized focus · coaxial illumination	1-51200	1-51204	1-51202
	12 mm manual focus	1-51319	1-51316	1-51337
	3 mm manual focus · coaxial illumination	1-51311	1-51315	1-51338
	No focus, no coaxial	1-51314	1-51317	1-51335
12x ultra motor zoom	No focus, with coaxial	1-51318	1-51306	1-51336
	12 mm motorized focus	1-51192	1-51208	1-51194
	3 mm motorized focus · coaxial illumination	1-51196	1-51210	1-51198
	12 mm manual focus	1-51325	1-51322	1-51333
	3 mm manual focus · coaxial illumination	1-51326	1-51321	1-51334
No focus, no coaxial	1-51320	1-51323	1-51331	
No focus, with coaxial	1-51324	1-51327	1-51332	
		Controller	Box Type	Panel Type
		Controller for 2 phase stepping motor	1-62420	2-62577
		Controller for 5 phase stepping motor	1-62506	2-62507
		Controller for DC servo motor	1-62508	2-62509
		Electrical power source	1-62504	
		USB cable	8-62502	
		RS232C cable	8-62501	

# NAVITAR x12 Ultra-zoom Lens

The x12 ultra zoom lens realizes amazing resolution and magnification in combination with an objective lens. If an infinity correction object lens is combined, the ultrahigh magnification zoom lens realizes high resolution (1650/mm or more) with long working distance and also high magnification (x320 max). This lens is optimum for high-magnification applications in the semiconductor and LCD inspection and medical and bio fields



x12 Ultra-zoom Lens

### Combinations

Since the x12 ultra zoom lens has a module-based design, the parts from (1) to (4) are combined to create a lens system.

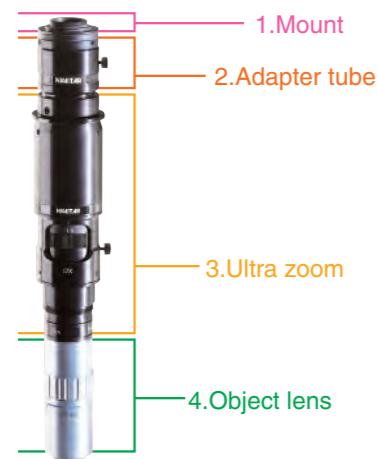

Product No.	
<b>1. Mount</b>	
1-6010	C mount adapter
<b>2. Adapter tube</b>	
1-61001	x0.67 mini-adapter
1-61400	x1 mini-adapter
1-62136	x2 mini-adapter
1-6245	x1 short adapter
1-6233	x2 short adapter
<b>3. Ultra zoom</b>	
1-50504	x12 ultra zoom with 12 mm fine focus
1-50503-M	x12 ultra coaxial zoom with 3 mm fine focus
<b>4. Object lens</b>	
8-60758	x2 object lens of WD = 32 mm (made by Mitsutoyo)
1-60226	x5 object lens of WD = 34 mm (made by Mitsutoyo)
1-60227	x10 object lens of WD = 33 mm (made by Mitsutoyo)
1-60228	x20 object lens of WD = 20 mm (made by Mitsutoyo)
1-60229	x50 object lens of WD = 13 mm (made by Mitsutoyo)

View of field data for x12 ultra zoom with objective lens

Objective lens	WD	CCDMagnification	x1 adapter tube		x2 adapter tube		
			Low	High	Low	High	
x2	32mm		x0.52 ~ x6.4		x1.04 ~ x12.8		
			2/3"	12.7x16.9x21.2	~ 1.03x1.38x1.72	6.4x8.5x10.6	~ 0.53x0.7x0.88
			1/2"	9.2x12.3x15.4	~ 0.75x1.00x1.25	4.6x6.2x7.7	~ 0.38x0.51x0.64
			1/3"	6.9x9.2x11.5	~ 0.56x0.75x0.94	3.5x4.6x5.8	~ 0.29x0.38x0.48
x5	34mm		x1.3 ~ x16		x2.6 ~ x32		
			2/3"	5.1x6.8x8.5	~ 0.41x0.55x0.69	2.5x3.4x4.2	~ 0.21x0.28x0.34
			1/2"	3.7x4.9x6.2	~ 0.3x0.4x0.5	1.9x2.5x3.1	~ 0.15x0.2x0.25
x10	33mm		x2.6 ~ x32		x5.2 ~ x64		
			2/3"	2.5x3.4x4.2	~ 0.21x0.28x0.34	1.3x1.7x2.1	~ 0.1x0.14x0.17
			1/2"	1.9x2.5x3.1	~ 0.15x0.2x0.25	0.92x1.2x1.5	~ 0.08x0.1x0.13
x20	20mm		x5.2 ~ x64		x10.4 ~ x128		
			2/3"	1.3x1.7x2.1	~ 0.1x0.14x0.17	0.63x0.85x1.1	~ 0.05x0.07x0.09
			1/2"	0.92x1.2x1.5	~ 0.08x0.1x0.13	0.46x0.62x0.77	~ 0.04x0.05x0.06
x50	13mm		x13 ~ x160		x26 ~ x320		
			2/3"	0.51x0.68x0.85	~ 0.04x0.06x0.07	0.25x0.34x0.42	~ 0.021x0.028x0.034
			1/2"	0.37x0.49x0.62	~ 0.03x0.04x0.05	0.18x0.25x0.31	~ 0.015x0.02x0.025
			1/3"	0.28x0.37x0.46	~ 0.02x0.03x0.04	0.14x0.18x0.23	~ 0.011x0.015x0.019

\*At low magnification, vignetting occurs on the monitor.

## DIC Differential Interference Module for Navitar 12x Ultra Zoom

By combining the DIC Differential Interference Module with the 12x Ultra Zoom, it is possible to emphasize and show in 3D uneven areas that are normally difficult to observe in work that has mirror-like surfaces, such as metal, precision processed surfaces, glass surfaces and wafer surfaces.

(Caution) The differential interference lens for the objective lens is recommended when using the objective lens.



Diagram of Unit Structure

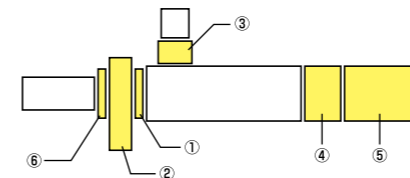

DIC Differential Interference Unit Structure

No.	Product No.	Product Name	Description
①	2-51370	M25x.75T Adapter	Connect main unit and DIC
②	1-63726	DIC Prism	DIC prism unit area
③	2-51485	Polarizer	Install between the lens main unit and the coaxial ferrule
	1-50554	Ferrule with Polarizer	Set product number for polarizer and coaxial ferrule
④	1-60816	Analyzer	Install between lens main unit and adapter tube
⑤	1-61997	1X RA T	Dedicated adapter tube 1x
	1-6120	2X RA	Dedicated adapter tube 2x
⑥	2-51370	M25x.75T Adapter	Connect with differential interference objective adapter manufactured by Nikon

\*Use of Mitutoyo and Olympus can be supported by using the adapter which is attached to the main unit of the ultra zoom.

### DIC Differential Interference Module Image

Without prism

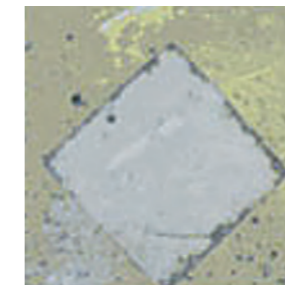

With prism

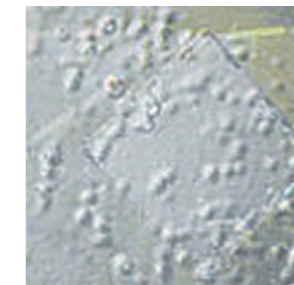

### Example of Zoom Image

Low power

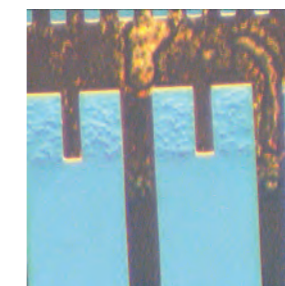

High power

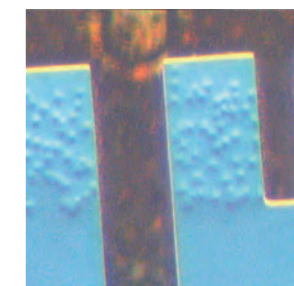



# Non-Telecentric Macro Lenses

## ML-N Series

- $\phi 16$ , COMPACT BODY
- HIGH RESOLUTION AND LOW TV DISTORTION
- REASONABLE PRICES
- Best matching with peripherals



ML-N Series lenses were developed to be compact, high performance models. Based on many years of experience producing MMLs (Machine Micro Lens), Moritex adopted the non-telecentric optical system as the lens design for this series. By limiting the number of lenses in each layer to less than 3, we have succeeded in developing high performance models at reasonable prices.

Magnification and working distances can be tailored to your needs by using an optional Close-Up ring adapter.

Model	Magnification	WD (mm)	Resolution	Depth of field	Effective Fno	TV distortion	Largest compatible CCD	Weight	Mount Sold separately	Commodity code
<b>ML01-327N</b>	x 0.1 $\pm$ 5%	327.7 $\pm$ 16.4	33.9 $\mu$ m	37.66mm	4.71	0.4% or less	1/2"	10g	C-mount	A-0133
<b>ML03-181N</b>	x 0.3 $\pm$ 5%	181.3 $\pm$ 9.1	14.6 $\mu$ m	5.43mm	6.11	0.2% or less	1/2"	15g	C-mount	A-0134
<b>ML05-132N</b>	x 0.5 $\pm$ 5%	132.5	11.7 $\mu$ m	1.95mm	6.08	0.08% or less	1/2"	18g	C-mount	A-0131
<b>ML1-89N</b>	x 1 $\pm$ 5%	89.6	7.9 $\mu$ m	0.7mm	8.82	0.04% or less	1/2"	15g	C-mount	A-0132

\*Depth of field is calculated assuming a horizontal 240 TV resolution using a 1/2" CCD camera. (Permissible circle of confusion on the image-formation side: 40 $\mu$ m)

■ The magnification can be changed by using the ML-EXR Series close-up rings.



Reference magnification and WD data for close-up ring combinations

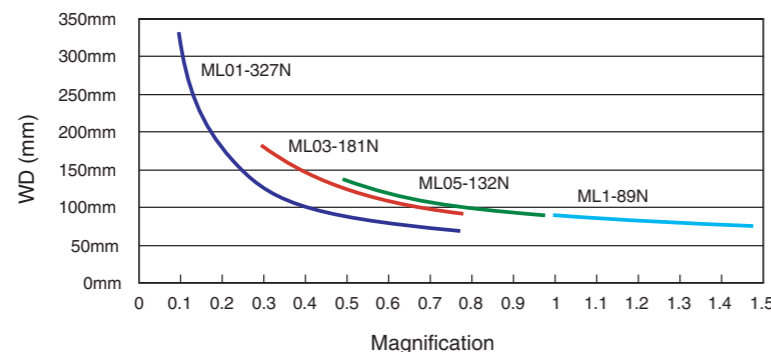

Magnification conversion table

Model	Close-up ring thickness	0mm	1mm	2mm	5mm	7mm	10mm	15mm	17mm	20mm
<b>ML01-327N</b>	Magnification	0.1x	0.13x	0.17x	0.27x	0.33x	0.43x	0.6x	0.67x	0.77x
	WD	327.7mm	253mm	204mm	138.8mm	118.6mm	97.5mm	77.7mm	72.5mm	67.2mm
<b>ML03-181N</b>	Magnification	0.3x	0.32x	0.35x	0.42x	0.47x	0.54x	0.65x	0.7x	0.77x
	WD	181.3mm	170mm	162mm	140.7mm	131mm	119mm	104.6mm	100mm	94.6mm
<b>ML05-132N</b>	Magnification	0.5x	0.53x	0.55x	0.62x	0.66x	0.73x	0.85x	0.9x	0.97x
	WD	132.5mm	128.4mm	125mm	116.3mm	111.3mm	105.2mm	97.4mm	94.2mm	91mm
<b>ML1-89N</b>	Magnification	1x	1.02x	1.05x	1.12x	1.16x	1.2x	1.35x	1.4x	1.47x
	WD	89mm	88mm	87mm	85mm	83.5mm	81.5mm	78.5mm	77.3mm	75.9mm



# Low Magnification Macro Lenses

Small, high-resolution macro lenses to be mounted directly on a machines. Working distance of all models is 90mm.

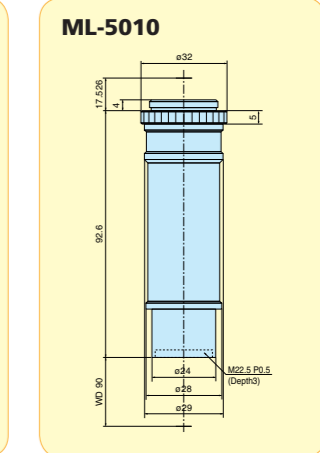
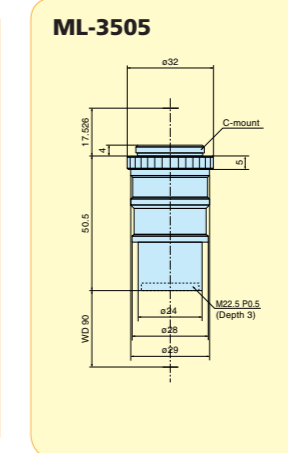
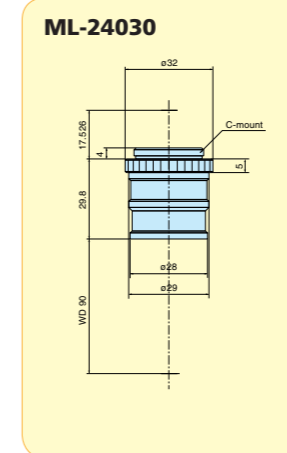
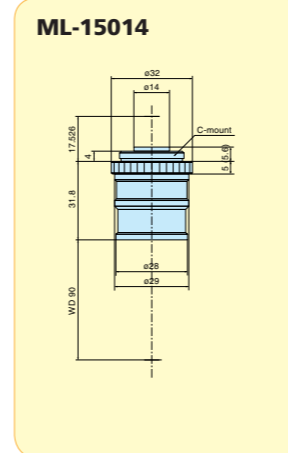

Model	Magnification	Effective Fno	WD	Depth of field	Resolution	TV distortion	Weight	Largest compatible CCD	Mount	Commodity code
<b>ML-15014</b>	x 0.14	4.6	90mm	18mm	36 $\mu$ m	0.1% or less	28g	2/3"	C-mount	A-0127
<b>ML-24030</b>	x 0.3	7.3	90mm	6.5mm	21 $\mu$ m	0.1% or less	39g	2/3"	C-mount	A-0128
<b>ML-3505</b>	x 0.5	8.4	90mm	2.7mm	13 $\mu$ m	0.1% or less	55g	2/3"	C-mount	A-0129
<b>ML-5010</b>	x 1	8	90mm	0.6mm	6.3 $\mu$ m	0.1% or less	68g	2/3"	C-mount	A-0130

\*Depth of field is calculated assuming a horizontal 240 TV resolution using a 1/2" CCD camera. (Permissible circle of confusion on the image-formation side: 40 $\mu$ m)

TV Macro Lens Options

Coaxial episcopic illumination unit appearance (MLZ-HM)

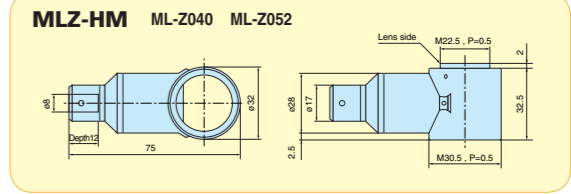

Mega Pixel Macro Zoom Lens

MLH-3XMP

Main uses



- Zoom: Optical magnification from x0.3 to x1
- Working distance: 90 mm
- Focusing: Variable
- Iris variation: Effective FNO4.5 to Close
- With operation lock screws (Zoom, focus, and iris)
- Maximum compatible camera format: Up to 2/3 inch
- C mount

This high-performance macro zoom lens supports CCD cameras of the one million pixel class. The zooming range is x0.3 to x1 by optical magnification. The resolution of 100/mm or more is realized at the center and periphery of the entire zooming area. Combining a mega-pixel CCD realizes wide-range image recognition with excellent contrast.

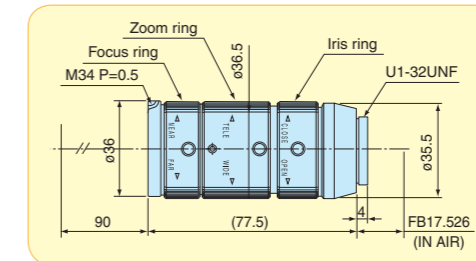

Model	MLH-3XMP
Magnification	x0.3 - x1 (manual zoom)
WD	90mm
Focus (Fno)	F4.5-Close
Filter screw	M34 P=0.5
Weight	150g
Largest compatible CCD	2/3"
Mount	C mount
Commodity code	A-0220



10x Zoom Lens MLH-10X

Main uses



- Zoom ratio of 10:1. (Magnification range: Min. 0.023X to Max. 0.84X)
- WD=Min. 450mm to Max. 150mm
- Iris, focus, and zoom are adjustable.
- Comes with locking screws.

A wide range zoom lens developed for wide field. Zoom ratio can be 10:1 at a working distance of 150mm to 450mm by adjusting the focus. This lens can be used for FA, laboratory work, weak eyesight correction, and environment-related projects.

Field of view chart

WD	Magnification	Field of view	
		1/2" (length mm x width mm)	1/3" (length mm x width mm)
150mm	x 0.086 ~ x 0.84	55.8 x 74.4 ~ 5.7 x 7.6	42 x 56 ~ 4.3 x 5.7
200mm	x 0.06 ~ x 0.58	80 x 107 ~ 8.3 x 11.0	60 x 80 ~ 6.2 x 8.3
250mm	x 0.045 ~ x 0.44	107 x 142 ~ 10.9 x 14.5	80 x 107 ~ 8.2 x 10.9
300mm	x 0.037 ~ x 0.36	130 x 173 ~ 13.3 x 17.8	97 x 130 ~ 10.0 x 13.3
350mm	x 0.031 ~ x 0.3	155 x 206 ~ 16.0 x 21.3	116 x 155 ~ 12.0 x 16.0
400mm	x 0.026 ~ x 0.25	185 x 246 ~ 19.2 x 25.6	138 x 185 ~ 14.4 x 19.2
450mm	x 0.023 ~ x 0.22	209 x 278 ~ 21.8 x 29.1	157 x 209 ~ 16.4 x 21.8

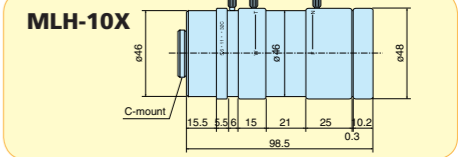

Model	MLH-10X
Magnification	x 0.084 ~ x 0.84
WD	150-450mm
Iris	F5.6-Close
Filter size	M46 P=0.75
Weight	233g
Largest compatible CCD	1/2"
Mount	C mount
Commodity code	A-0149

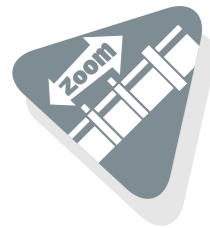

TV Macro Zoom Lens

- Zoom ratio of 4:1. (0.02X to 2.4X) Eight models are available.
- Iris, focus, and zoom are adjustable.
- Include screws to lock movable parts.
- Maximum outside diameter: 25mm

CCTV simplified zoom models. Various types of images can be taken because the products are small, light weight, and very functional.

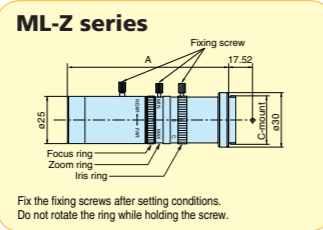

Model	ML-Z002	ML-Z004	ML-Z007	ML-Z014	ML-Z020	ML-Z026	ML-Z040	ML-Z052
WD(mm)max~min	750~300	750~300	210~150	210~150	69~55	49~44	69~55	49~44
Magnification	x0.02~x0.08	x0.06~x0.22	x0.044~x0.16	x0.12~x0.43	x0.07~x0.25	x0.11~x0.39	x0.14~x0.51	x0.21~x0.77
Depth of field (mm)	±387~±30	±51~±3.9	±202~±15	±28~±2.1	±37~±2.7	±16~±1.2	±19~±1.5	±8.3~±0.6
Effective Fno	4.6~22	9.2~44	4.6~22	9.2~44	4.6~22	9.2~44	4.6~22	9.2~44
Weight (g)	94	101	94	102	103	103	110	111
Largest compatible CCD	1/2"	1/2"	1/2"	1/2"	1/2"	1/2"	1/2"	1/2"
Mount	C-mount	C-mount	C-mount	C-mount	C-mount	C-mount	C-mount	C-mount
Commodity code	A-0136	A-0137	A-0138	A-0139	A-0140	A-0141	A-0142	A-0143



High-performance Macro Zoom Lens ML-Z0108

- Zoom ratio of 8:1. Magnification range: 0.1x to 0.8x
- WD=213mm
- Focus adjustment ±20mm (magnification variation ±13%)
- Iris, focus, and zoom are adjustable.
- Comes with locking screws.

High-resolution macro lens with 8:1 magnification ratio and long working distance. By using the focus ring on the tip, working distance can be changed within a range of 20mm.

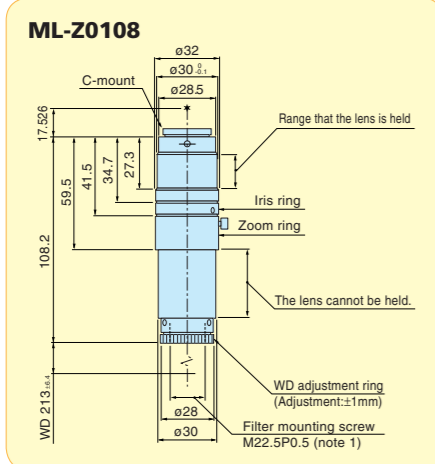

Model	ML-Z0108		
Optical magnification	0.1X to 0.8X (zoom ratio of 8:1)		
WD	213mm		
Focus adjustment	±20mm (amount the lens comes out ±1mm, magnification variation ±13%)		
	at 0.1X	at 0.4X	at 0.8X
Effective Fno	8.2	9.3	
Depth of field	32.8mm	2.1mm	0.6mm
Resolution	55µm	14µm	8µm
TV distortion	-0.02%or less	0.18%or less	0.17%or less
Operation function	Manual: Adjusting iris, zoom, and focus		
Weight	140g		
Largest compatible CCD	1/2"		
Mount	C-mount		
Commodity code	A-0155		

\*Depth of field is calculated assuming a horizontal 320 TV resolution using a 1/2" CCD camera. (Permissible circle of confusion on the image-formation side: 40µm)  
\*Effective FNO indicates a value when the iris is open.

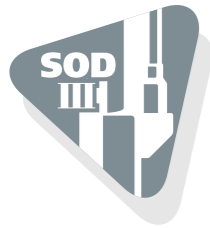

## Coaxial Epiillumination Unit for Objective lens **SOD-III Series**

- Compact design
- Compatible with various makers bright field lenses
- Mount in many different ways such as horizontal setting

SOD-III is an optical unit used for coaxial epi-illumination with objective lenses. If you are using a metallurgical microscope, this unit is effective for image input because it produces video of the same level. This unit is designed for infinity correction objective lens (bright vision) and can be used with the lenses listed below. In addition to the monocular type, the 5-hole revolver type (manual or electric) allows for the mounting of five objective lenses is available.



## High Power Objective Lens Sliding Changer **SOD-SRV Series**

The objective lens has been changed to high speed by using a new slide mechanism. Rapid and highly accurate online inspection has been achieved.

- Ultra high speed Variable power Maximum  $\leq 0.33$  seconds
- High accuracy Repeated positioning  $\pm 1.5\mu\text{m}$
- High durability 50 million times
- WD adjustment function
- Image positioning adjustment function
- Independent Operation panel
- USB 2.0 External control



The magnification power is changed by sliding 5 objective lenses on the X- and Y- axes. This achieves high speed, high accuracy, and high durability when compared to the conventional revolution method. Also, unique new functions provide smooth installation and adjustment when loading onto machines.

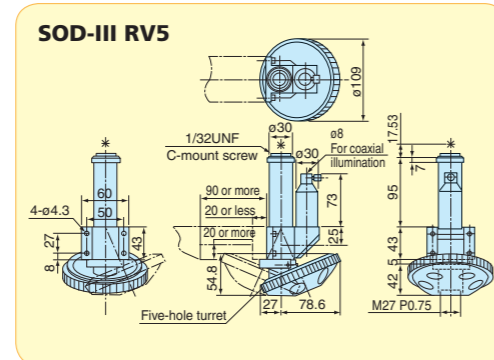
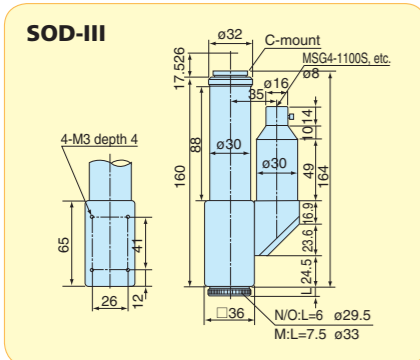

SODIII RV5

Model	SOD-III	SOD-III RV5	SOD-III RV5M
Remarks	—	Five-hole manual revolver type	Five-hole electric revolver type
Commodity code	A-0171	A-0172	A-0173

### Compatible object lenses



#### Mitsutoyo

Model	NA	WD(mm)	Commodity code
M Plan Apo 2 X	0.055	34	A-8132
M Plan Apo 5 X	0.14	34	A-8133
M Plan Apo 10 X	0.28	33.5	A-8134
M Plan Apo 20 X	0.42	20	A-8137
M Plan Apo SL 20 X	0.28	30.5	A-8135
M Plan Apo SL 50 X	0.42	20.5	A-8136

#### Nikon

Model	NA	WD(mm)	Commodity code
CF IC EPI Plan 2.5 X	0.075	8.8	A-8143
CF IC EPI Plan 5 X	0.13	22.5	A-8144
CF IC EPI Plan 10 X	0.3	16.5	A-8148
CF IC EPI SLWDPlan 10 X	0.21	20.3	A-8145
CF IC EPI SLWDPlan 20 X	0.35	20.5	A-8146
CF IC EPI SLWDPlan 50 X	0.45	13.8	A-8147



2 hole type

### SOD-SRV Structure

Product Name	Model	Notes
Lens barrel	<b>SOD-III</b>	Infinity objective unit
Slide area	<b>LV-SRV2H6</b>	2 hole type
	<b>LV-SRV3H6</b>	3 hole type
	<b>LV-SRV-5H6</b>	5 hole type
	<b>LV-SRV-6H4</b>	6 hole type
Control box	<b>LV-SRCR</b>	Control box for X- and Y-axis motors
Control panel	<b>LV-SRO9</b>	1 meter cable attached
XY control cable	<b>CV-3N</b>	1 cable required for both X- and Y-axis (3 m)
Objective lens adapter double ring (2 rings in 1 set)	<b>OBN20</b>	For diameter 20.32:
	<b>OBN25</b>	1 set for each
	<b>OBN26</b>	For M25:Mitsutoyo
	<b>OBN27</b>	For M27:Nikon

\*Stand, objective lens and CCD camera are not included.

### Main Specifications (SRV-5H6)

Basic Power	5X, 10X, 20X, 50X, 100X
Ultra High Speed Slide	Max $\leq 0.33$ seconds / Min $\leq 0.53$ seconds
Repeated Positioning	$\pm 1.5\mu\text{m}$
Durability	50 million times
Slide Area Weight	4kg
Pressure Resistance	Approximately 15 kg
Electrical Power Source	AC90V-240V
Peripheral Equipment (Option)	Image Auto Focus
	Laser Auto Focus
	Z-axis Stage Controller

2 hole and 3/9 hole types are also available. Parts are also sold separately. Moritex offers special orders to support customer equipment.



6 hole type

Main uses: High-accuracy inspection by line CCD (LCD glass, color filter, and board)  
Appearance inspection and alignment by large mega-pixel area CCD (300 mm wafer, LCD glass, board, etc.)

Main uses: Wafer inspection, Lead frame inspection, Package board inspection, Film inspection



# Line CCD Lens

## Macro Lenses for Line CCDs, for 57mm Sensor



- Advanced optical design for maximum 8000 bit (57.3mm)
- Advanced optical design for 1 mega-pixel (>=2 million bit) area CCD
- Adjustable magnification (0.2X-0.35X or 0.35X-0.5X)
- Low chromatic aberration & Low distortion.
- Adapters for camera mount variations.

High performance Line CCD lenses for maximum 8000 bit (element size:57.3mm) line sensor. Flexible design allows fine magnification setup by focus adjustment. Outstanding performance is achieved by minimizing RGB color chromatic aberration/distortion. Optional mounts accept various camera mount. This series is designed not only for the maximum 57mm (7µm/Pix) Image format but also for the large area CCD Sensor (MAX40mm).

### ML-L02035

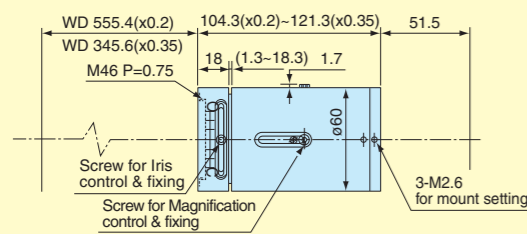

### ML-L03505

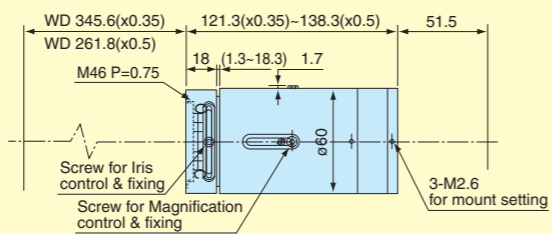

Model	Magnification	Zoom position	WD(mm)	Effective Fno	Depth of field	Resolution	Distortion	Weight	Largest compatible CCD	Mount	Commodity code
ML-L02035	x0.2~x0.35 Manual	atx0.2	555.4±16.6	5.8~32	1.1mm	19.3µm	±0.1% or less	750g	ø57.3mm	Mount Adapter (Options)	A-0184
		atx0.35	345.6±10.4	6.6~36.6	475µm	12.6µm					
ML-L03505	x0.35~x0.5 Manual	atx0.35	345.6±10.4	6.6~36.6	475µm	12.6µm	±0.1% or less	800g	ø57.3mm	Mount Adapter (Options)	A-0185
		atx0.5	261.7±7.8	7.4~41	295µm	10µm					

\*Depth of field is calculated from resolution.  
\*Resolution indicates a theoretical resolution at 550nm wavelength.

### Camera mounts (Optional)

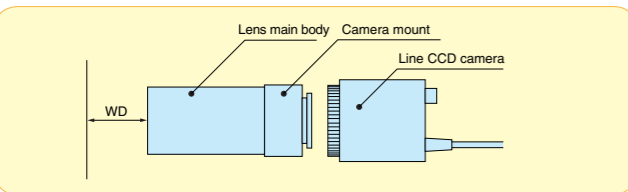

Model	FMT-S	CMT-S
Mount Name	Nikon F mount	C mount
Commodity Code	A-0193	A-0194

### P2MT-S (DALSA Piranha 2 mount)

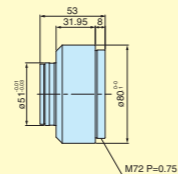

### P3MT-S (DALSA Piranha 3 mount)

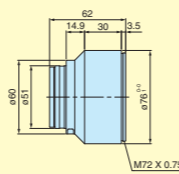

### FMT-S (Nikon F mount)

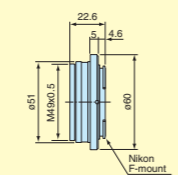

### CMT-S (C mount)

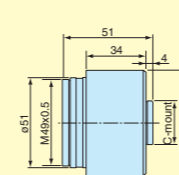

★Moritex also prepares mounts of all other manufacturers.



# Macro Lenses for Line CCDs

## ML-L Series



- Optimal for high speed processing for high fields of vision.
- Low TV distortion, all models less than 0.1%
- Low marginal rays difference
- High resolution, high contrast
- Suitable for long WD applications

### ML-L05

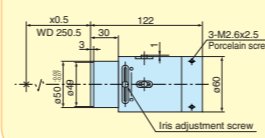

### ML-L07

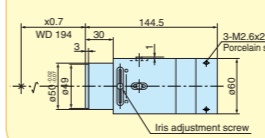

### ML-L09

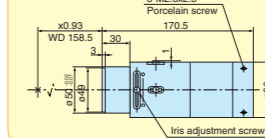

### ML-L14

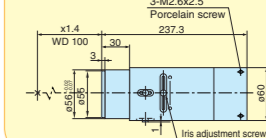

### ML-L047-200 Made-to-order

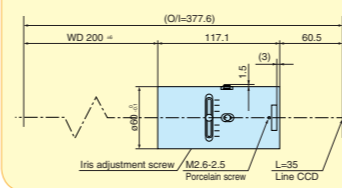

Model	Magnification	Effective Fno	WD	Depth of field	Resolution	TV distortion	Weight	Mount(Sold separately)	Commodity code
ML-L05	x0.5	5.9~28	250.5mm	470µm	20µm	0.1% or less	700g	MMT / FDMT / FMT / CMT(See below)	A-0179
ML-L07	x0.7	6.7~32	194mm	270µm	14µm	0.1% or less	800g	MMT / FDMT / FMT / CMT(See below)	A-0180
ML-L09	x0.933	7.7~37	158.5mm	160µm	10µm	0.1% or less	800g	MMT / FDMT / FMT / CMT(See below)	A-0181
ML-L14	x1.4	9.5~45	100mm	95µm	7µm	0.1% or less	800g	MMT / FDMT / FMT / CMT(See below)	A-0182
ML-L047-200	x0.47	5.9~32	200mm	300µm	12µm	0.01% or less	720g	MMT / FDMT / FMT / CMT(See below)	A-0183

\*Depth of field is calculated based on resolution.

### Camera mounts (Optional)

Model	MMT	FDMT	FMT	CMT
Mount	NED compatible mount	Canon mount	Nikon mount	C mount
Commodity code	A-0191	A-0190	A-0189	A-0192

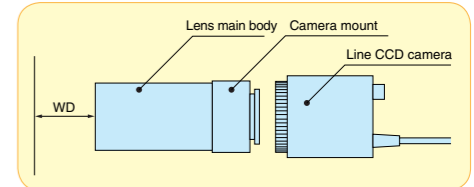

### MMT

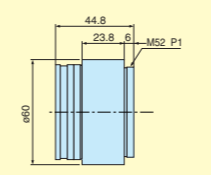

NED compatible out

### FDMT

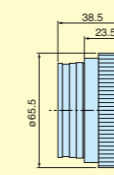

Canon mount

### FMT

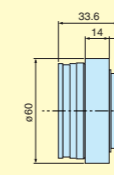

Nikon mount

### CMT

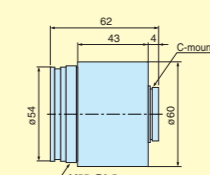

C mount

### Line CCD camera element list

Model
14µm x 1024bit
11µm x 2048bit
11µm x 2592bit
7µm x 5000bit
4.7µm x 5000bit
4.7µm x 7500bit



# CCTV lenses



- A wide range of products from f=6mm to 100mm.
- Focus and iris are adjustable using attached locking screws.
- Camera mount: C mount

CCTV (Closed Circuit Television) lenses were developed to recognize images in a wide area. All models have an iris and focus adjustment that you can set as required with the included locking screws (\*1).

Using optional close-up ring and converter lenses allows for macro photography. (\*2).

\*1 Not designed to be vibration proof.

\*2 Tolerances of lenses may increase and image quality may worsen as a result.

ML-0614

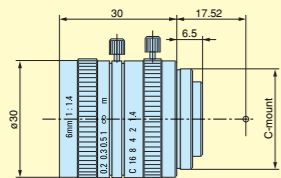

ML-0813

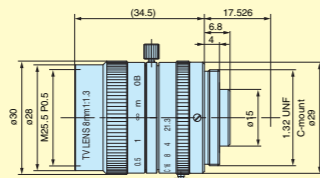

ML-1214

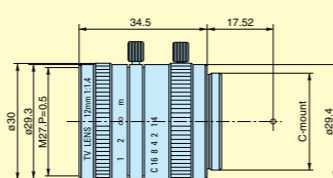

ML-1614

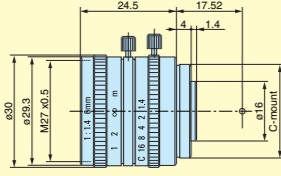

ML-2514

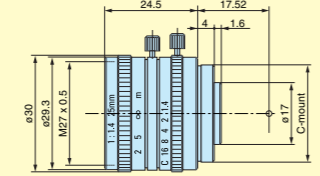

ML-3519

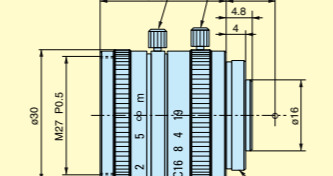

ML-5018

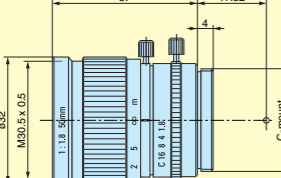

ML-7527

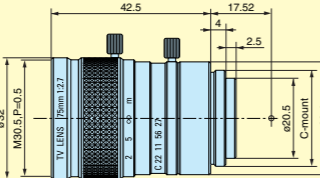

ML-10035

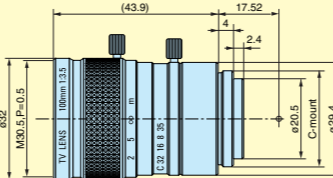

## Field, WD, and magnification when a close-up ring is used

Close-up ring (mm)	ML-0614				ML-0813				ML-1214			
	Field of view(length x width)		WD (mm)	Magnification	Field of view(length x width)		WD (mm)	Magnification	Field of view(length x width)		WD (mm)	Magnification
	1/2"	1/3"			1/2"	1/3"			1/2"	1/3"		
0	165 x 221	124 x 165	200	0.03	96 x 128	72 x 96	148	0.05	103 x 137	77 x 103	248	0.05
0.5	44 x 58	33 x 44	43	0.11	43 x 57	32 x 43	59	0.11	55 x 73	41 x 55	125	0.09
	60 x 79	45 x 60	63	0.08	77 x 102	57 x 77	115	0.06	119 x 159	89 x 119	289	0.04
1	25 x 34	19 x 25	19	0.19	27 x 37	21 x 27	34	0.18	38 x 50	28 x 38	80	0.13
	30 x 40	22 x 30	25	0.16	38 x 51	29 x 38	52	0.13	59 x 79	45 x 59	136	0.08
1.5					20 x 27	15 x 20	22	0.24	29 x 38	21 x 29	57	0.17
					26 x 34	19 x 26	31	0.19	40 x 53	30 x 40	85	0.12
2									23 x 31	17 x 23	42	0.21
									30 x 40	22 x 30	59	0.16

Close-up ring (mm)	ML-1614				ML-2514				ML-3519			
	Field of view(length x width)		WD (mm)	Magnification	Field of view(length x width)		WD (mm)	Magnification	Field of view(length x width)		WD (mm)	Magnification
	1/2"	1/3"			1/2"	1/3"			1/2"	1/3"		
0	109 x 145	82 x 109	358	x0.04	87 x 115	65 x 87	458	x0.06	66 x 87	49 x 66	500	x0.07
0.5	64 x 86	48 x 64	206	x0.07	64 x 85	48 x 64	338	x0.08	55 x 73	41 x 55	422	x0.09
	156 x 208	117 x 156	515	x0.03	242 x 322	181 x 242	1270	x0.02	335 x 447	251 x 335	2459	x0.01
1	45 x 61	34 x 45	143	x0.11	50 x 67	38 x 50	269	x0.10	47 x 63	35 x 47	366	x0.10
	78 x 104	58 x 78	252	x0.06	121 x 161	91 x 121	637	x0.04	168 x 223	126 x 168	1240	x0.03
1.5	35 x 47	26 x 35	108	x0.14	42 x 56	31 x 42	223	x0.12	41 x 55	31 x 41	324	x0.12
	52 x 69	39 x 52	164	x0.09	81 x 107	60 x 81	425	x0.06	112 x 149	84 x 112	834	x0.04
2	29 x 38	22 x 29	86	x0.17	36 x 47	27 x 36	191	x0.13	37 x 49	28 x 37	291	x0.13
	39 x 52	29 x 39	120	x0.12	60 x 81	45 x 60	320	x0.08	84 x 112	63 x 84	631	x0.06
5	14 x 18	10 x 14	35	x0.35	19 x 25	14 x 19	103	x0.25	22 x 30	17 x 22	185	x0.22
	16 x 21	12 x 16	42	x0.31	24 x 32	18 x 24	130	x0.20	34 x 45	25 x 34	265	x0.14
10	7.3 x 9.7	5.4 x 7.3	14	x0.66	11 x 14	8.0 x 11	60	x0.45	13 x 18	10 x 13	121	x0.36
	7.8 x 10	5.8 x 7.8	15	x0.62	12 x 16	9.1 x 12	66	x0.40	17 x 22	13 x 17	143	x0.29
15					7.4 x 9.8	5.5 x 7.4	43	x0.65	9.5 x 13	7.2 x 9.5	93	x0.50
					8.1 x 11	6.0 x 8.1	45	x0.60	11 x 15	8.4 x 11	103	x0.43
20					5.6 x 7.5	4.2 x 5.6	34	x0.85	7.4 x 9.9	5.6 x 7.4	78	x0.65
					6.0 x 8.1	4.5 x 6.0	35	x0.79	8.4 x 11	6.3 x 8.4	82	x0.57
25									6.1 x 8.1	4.6 x 6.1	68	x0.79
									6.7 x 8.9	5.0 x 6.7	70	x0.72

Close-up ring (mm)	ML-5018				ML-7527				ML-10035			
	Field of view(length x width)		WD (mm)	Magnification	Field of view(length x width)		WD (mm)	Magnification	Field of view(length x width)		WD (mm)	Magnification
	1/2"	1/3"			1/2"	1/3"			1/2"	1/3"		
0	90 x 120	68 x 90	943	x0.05	60 x 80	45 x 60	1000	x0.08	46 x 62	35 x 46	1000	x0.10
1.5	57 x 76	43 x 57	610	x0.08								
	154 x 205	115 x 154	1577	x0.03								
2	51 x 67	38 x 51	548	x0.10	43 x 57	32 x 43	776	x0.11				
	115 x 154	86 x 115	1193	x0.04	184 x 246	138 x 184	3189	x0.03				
5	31 x 41	23 x 31	347	x0.16	30 x 40	23 x 30	607	x0.16	27 x 37	21 x 27	724	x0.18
	46 x 61	35 x 46	503	x0.10	74 x 98	55 x 74	1422	x0.07	95 x 127	71 x 95	2413	x0.05
10	18 x 25	14 x 18	226	x0.26	20 x 27	15 x 20	475	x0.24	19 x 26	15 x 19	609	x0.25
	23 x 31	17 x 23	273	x0.21	37 x 49	28 x 37	833	x0.13	48 x 63	36 x 48	1432	x0.10
15	13 x 18	10 x 13	174	x0.37	15 x 20	11 x 15	408	x0.32	15 x 20	11 x 15	546	x0.32
	15 x 21	12 x 15	196	x0.31	25 x 33	18 x 25	636	x0.20	32 x 42	24 x 32	1105	x0.15
20	10 x 14	7.7 x 10	145	x0.47	12 x 16	9 x 12	369	x0.40	12 x 16	9 x 12	505	x0.39
	12 x 15	8.6 x 12	158	x0.42	18 x 25	14 x 18	538	x0.26	24 x 32	18 x 24	941	x0.20
25	8.4 x 11	6.3 x 8.4	126	x0.57	10 x 14	7.6 x 10	342	x0.47	10 x 14	8 x 10	478	x0.46
	9.2 x 12	6.9 x 9.2	134	x0.52	15 x 20	11 x 15	479	x0.33	19 x 25	14 x 19	843	x0.25
30	7.1 x 9.4	5.3 x 7.1	113	x0.68	8.7 x 12	6.5 x 8.7	323	x0.55	9.0 x 12	6.7 x 9.0	458	x0.54
	7.7 x 10	5.8 x 7.7	119	x0.63	12 x 16	9.2 x 12	440	x0.39	16 x 21	12 x 16	778	x0.30
35	6.1 x 8.2	4.6 x 6.1	104	x0.78	7.6 x 10	5.7 x 7.6	309	x0.63	7.9 x 11	5.9 x 7.9	443	x0.61
	6.6 x 8.8	4.9 x 6.6	108	x0.73	11 x 14	7.9 x 11	412	x0.46	14 x 18	10 x 14	731	x0.35
40	5.4 x 7.2	4.1 x 5.4	97	x0.89	6.7 x 9.0	5.1 x 6.7	297	x0.71	7.1 x 9.4	5.3 x 7.1	430	x0.68
	5.8 x 7.7	4.3 x 5.8	100	x0.83	9.2 x 12	6.9 x 9.2	391	x0.52	12 x 16	8.9 x 12	696	x0.40
45					6.1 x 8.1	4.6 x 6.1	289	x0.79	6.4 x 8.5	4.8 x 6.4	421	x0.75
					8.2 x 11	6.1 x 8.2	375	x0.59	11 x 14	7.9 x 11	669	x0.45
50					5.5 x 7.4	4.1 x 5.5	281	x0.87	5.8 x 7.8	4.4 x 5.8	412	x0.82
					7.4 x 9.8	5.5 x 7.4	361	x0.65	9.5 x 13	7.1 x 9.5	647	x0.50
60									5.0 x 6.6	3.7 x 5.0	400	x0.97
									7.9 x 11	5.9 x 7.9	614	x0.61

● Indicated values are based on calculations and actual measurements may be different. Use the values as a reference.

● Products' accuracy is guaranteed only when themselves use them. Please note that WD, distortion, and image quality may vary when a close-up ring or other equipment is used because tolerances of lenses increase.



# Mega Pixel CCTV Lens Series

- Lineup of five models (f = 8 to 50 mm)
- Supporting mega-pixel cameras
- Focus and iris variable
- With operation lock screws (Focus and iris)
- Maximum compatible camera format: Up to 2/3 inch
- C mount



The Mega-pixel CCTV Series provides monitor lenses developed for wide-area image recognition with higher definition. The greatest feature resolvable is 100/mm and these lenses offer high resolution both at the center and the periphery. If used with a mega-pixel camera, the lenses allow photographing with higher resolution and contrast than the conventional CCTV. For all models, the variable iris and focus (with lock screw) can be fixed at arbitrary positions (\*1). The lenses also support macro photographing in combination with a close-up ring and a rear converter lens (\*2).

\*1 Vibration resistance is not considered in design.  
\*2 If a close-up ring and a rear converter lens are used, an enlarged lens tolerance cause an individual difference in product performance or image deterioration  
Note: The product performance is guaranteed only if the product is used alone.

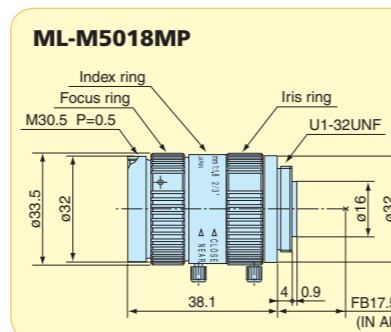
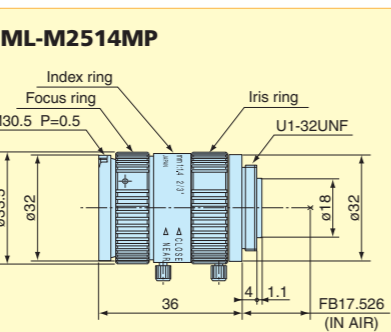
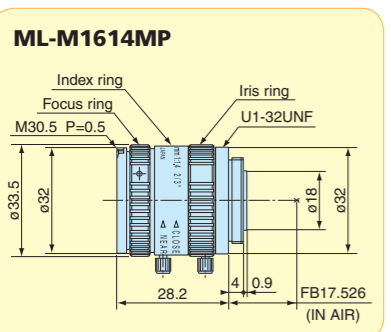
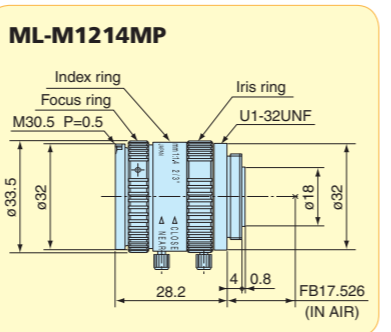
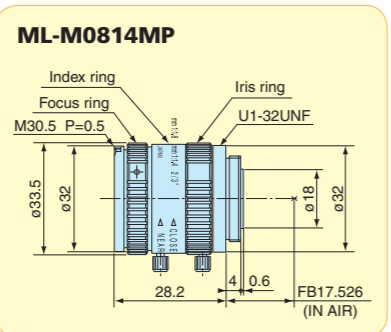
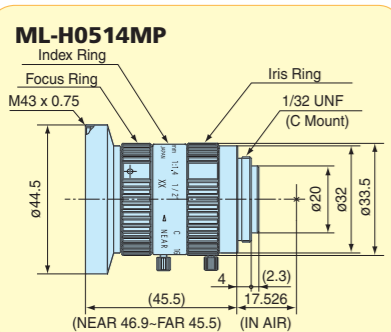

Model	Focus Distance (f)	Aperture (Fno)	Field Angle	Closest distance	Filter Screw	Weight	Largest compatible CCD	Mount	Commodity Code
ML-H0514MP	5mm	F1.4~16C	51.4°x65.5°	0.3m	M43 P0.75	107g	1/2"	C-Mount	A-3100
ML-M0814MP	8mm	F1.4~16C	43.7°x56.3°	0.1m	M30.5 P0.5	70g	2/3"	C-Mount	A-0221
ML-M1214MP	12mm	F1.4~16C	30.8°x40.4°	0.15m	M30.5 P0.5	65g	2/3"	C-Mount	A-0222
ML-M1614MP	16mm	F1.4~16C	23.4°x30.8°	0.3m	M30.5 P0.5	65g	2/3"	C-Mount	A-0223
ML-M2514MP	25mm	F1.4~16C	15.1°x20°	0.3m	M30.5 P0.5	75g	2/3"	C-Mount	A-0224
ML-M5018MP	50mm	F1.8~16C	7.9°x10.5°	0.5m	M30.5 P0.5	90g	2/3"	C-Mount	A-0225



# Telecentric CCTV lens MTE-55

The MTE-55 lens uses F2.8, f=55mm telecentric optical system that reduces angle and magnification errors when observing objects. Accurate telecentric performance is achieved when combined with the optional lens MTE2 with magnification of 0.4X to 0.9X. Although there is no telecentric effect at the magnification of infinite to 0.4X, aberrations are corrected well as compared to regular lenses.

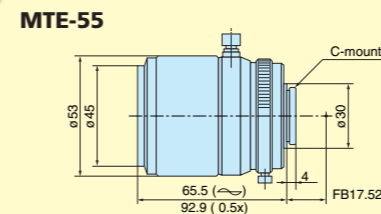

Field of view by CCD camera size (MTE-55)

WD (mm)	MTE-55			Optical magnification
	2/3" (length x width)	1/2" (length x width)	1/3" (length x width)	
5000	550x733	415x550	300x400	x0.012
3000	330x440	240x320	170x220	x0.02
1000	132x176	090x120	61x82	x0.05
500	55x73	40x53	30x40	x0.12
300	31x41	24x32	17x22	x0.21
200	22x29	15x20	11x15	x0.3
140	13x18	10x13	07x10	x0.48

Model	MTE-55
Magnification	Infinite to 0.5X (when a special converter is used: 1.0X at max)
Focal distance	F=55mm
Fno	2.8-close
Photographing distance	Infinite to 140mm
Distortion	0.6% at max
Marginal ray amount	78.50%
Mount	C-mount
Filter size	M43 P=0.75
Largest compatible CCD	2/3"
Weight (g)	320g
Commodity code	A-0212

## Options

x2 converter lens (MTE2)

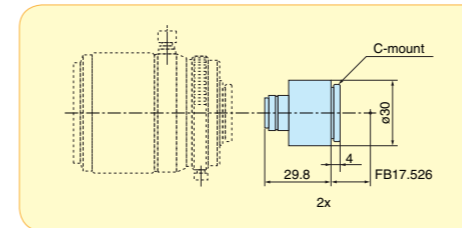

Dedicated x2 converter lens	MTE2
Commodity code	A-8083

x0.75 converter lens (MTE075)

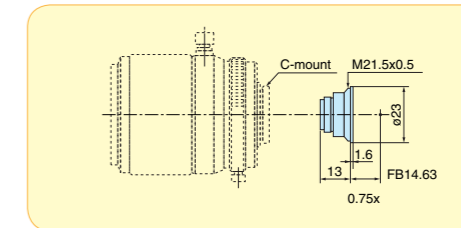

Dedicated x0.75 converter lens	MTE075
Commodity code	A-8084

Field of view by CCD camera size (MTE-55+MTE2)

WD (mm)	MTE-55 +Special 2X converter(MTE2)			Optical magnification
	2/3" (length x width)	1/2" (length x width)	1/3" (length x width)	
5000	275x366	207x275	150x200	x0.024
3000	165x220	120x160	85x110	x0.04
1000	66x88	45x60	30x41	x0.1
500	27x36	20x26	15x20	x0.24
300	15x20	12x16	8x11	x0.42
200	11x14	07x10	5x7	x0.6
140	6x9	5x6	3x5	x0.9

Field of view by CCD camera size (MTE-55 + MTE075)

WD (mm)	MTE-55 +Special 0.75X converter(MTE075)			Optical magnification
	2/3" (length x width)	1/2" (length x width)	1/3" (length x width)	
5000	733x977	553x733	400x533	x0.009
3000	440x586	320x426	226x293	x0.015
1000	176x234	120x160	081x109	x0.03
500	73x97	53x70	40x53	x0.09
300	41x54	32x42	22x29	x0.15
200	29x38	20x26	14x20	x0.22
140	17x24	13x17	09x13	x0.36



# Option

## Rear converter lens

Attach these lenses between a CCTV lens and a CCD camera to adjust the magnification without changing the working distance of the system.

\*Note that using them lowers the resolution.



Configuration

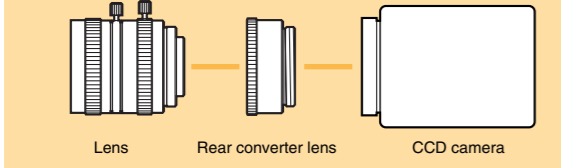

Model	Commodity code
<b>ML-1.5X</b>	A-8090
<b>ML-2X</b>	A-8091
<b>ML-2.5X</b>	A-8092
<b>ML-3X</b>	A-8093
<b>ML-4X</b>	A-8094

**ML-1.5X**

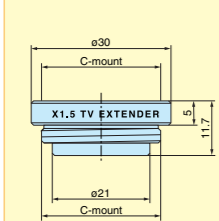

**ML-2X**

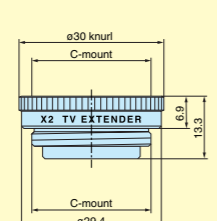

**ML-2.5X**

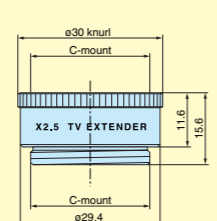

**ML-3X**

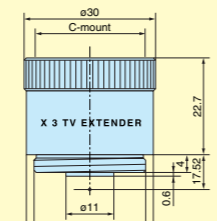

**ML-4X**

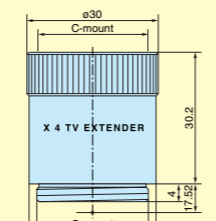

## 90° Mirror Prism for CCTV

### ML-MLC

- Full support for CCTV M25.5, 27, and 30.5.
- Screw for attachment to filters.

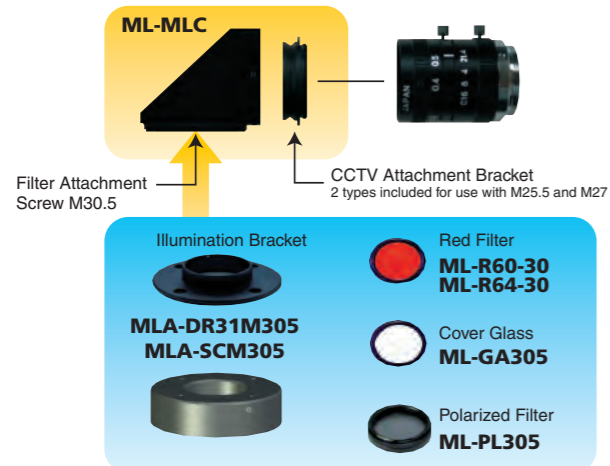

**ML-MLC**

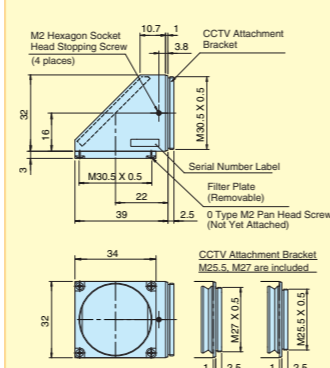

Model	Commodity code
<b>ML-MLC</b>	A-8014

## Option for CCTV Lens

Glass Cover **ML-GA**



A cover glass adapter for preventing the adhesion of dirt and foreign objects to the lens surface.

Deflection Filter **ML-PL**



A deflection filter adapter with revolution function that suppresses glare and localized variation of work when used as a set with deflection illumination.

Ring Illumination Attachment Adaptor **ML-FL**



Adaptor ML-FL with ring illumination.

Option

Screw Pitch	255		270		305	
	Model	Commodity code	Model	Commodity code	Model	Commodity code
Glass Cover	<b>ML-GA255</b>	A-8059	<b>ML-GA270</b>	A-8060	<b>ML-GA305</b>	A-8061
Polarizing Filter	<b>ML-PL255</b>	A-8067	<b>ML-PL270</b>	A-8068	<b>ML-PL305</b>	A-8069
Polarizing Filter (with locking screw)	<b>ML-PL255LB</b>	A-3130	<b>ML-PL270LB</b>	A-3131	<b>ML-PL305LB</b>	A-3132
Ring Illumination Attachment Adapte	<b>ML-FL255</b>	A-8075	<b>ML-FL270</b>	A-8076	<b>ML-FL305</b>	A-8077
Red Filter	<b>ML-R60-25</b>	A-8031	<b>ML-R60-27</b>	A-8032	<b>ML-R60-30</b>	A-8033
Sharp Cut Filter	<b>ML-R64-25</b>	A-9055	<b>ML-R64-27</b>	A-9056	<b>ML-R64-30</b>	A-9057
Close-Up Ring	<b>ML-EXR / ML-EXR1520 / ML-EXR3042</b>					

## Close-Up Ring

Used when using the CCTV lens at close range or when enlarging the magnification. Refer to page 57 for a chart comparing field of vision, WD, and magnification when close-up ring.



Model	Notes	Commodity code
<b>ML-EXR</b>	Set of 7 (0.5, 1, 2, 5, 10, 20, 40)	A-8100
<b>ML-EXR05</b>	0.5mm	A-8101
<b>ML-EXR1</b>	1mm	A-8102
<b>ML-EXR2</b>	2mm	A-8103
<b>ML-EXR5</b>	5mm	A-8104
<b>ML-EXR10</b>	10mm	A-8105
<b>ML-EXR15</b>	15mm	A-8106
<b>ML-EXR20</b>	20mm	A-8107
<b>ML-EXR25</b>	25mm	A-8108
<b>ML-EXR30</b>	30mm	A-8109
<b>ML-EXR40</b>	40mm	A-8110
<b>ML-EXR50</b>	50mm	A-8111
<b>ML-EXR100</b>	100mm	A-8112
<b>ML-EXR1520</b>	Variable type (15 to 20 mm)	A-8113
<b>ML-EXR3042</b>	Variable type (30 to 42 mm)	A-8114

# Telecentric Lens VISIONMES®

Carl Zeiss



Outstanding Capabilities Realize the Ultimate Measuring Environment

- The ultimate in distortion free images.
- Able to recognize accurate images of the structure and form of complicated objects.
- A high capability optical lens that boasts quality at the HDTV level.
- A diffraction-limited image is achieved through high resolution.
- A bright image can be obtained even in short exposure time thanks to a high numerical aperture.
- A module design that considers connection of standard CCD matrix cameras.
- Lineup offering a maximum opening diameter of 300 mm.
- Solid design.
- Supports 1/3", 1/2", 2/3" and 1" CCD cameras.
- Support for CCD cameras of 1" or greater upon request.

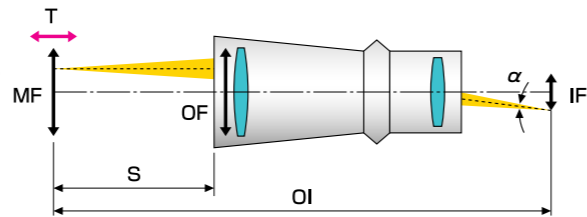

MF Measurement field  
OF Object field  
IF Image field  
OI Distance between object images  
S Working distance (WD)  
T Telecentric Range  
sin  $\alpha$  Numerical aperture  
Mag. Magnification power

Measurement range (vertical mm x horizontal mm)  
Lens opening diameter at object side (diameter mm)  
CCD element surface  
images Distance from object surface to CCD element  
Distance from tip of metal material to focus position  
Range in which measurement of an accurate image is possible even if the work moves up and down  
Image field / Object field

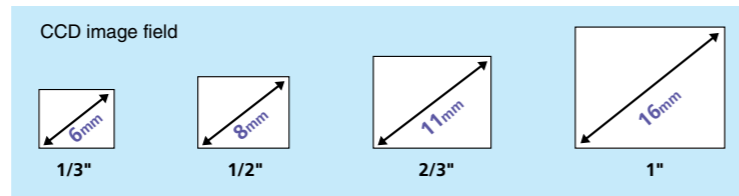
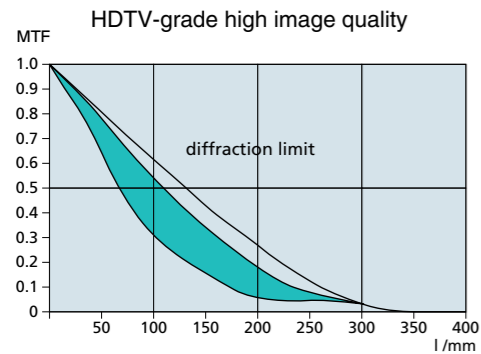

## Examples Images

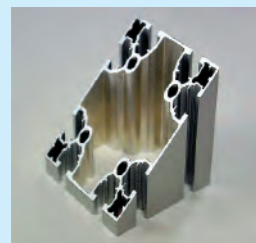

Image of CCTV lens

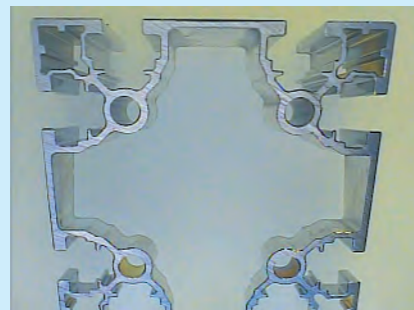
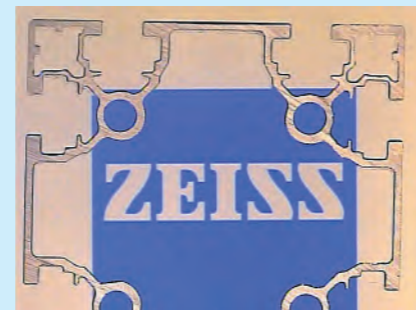

Image of telecentric lens



## Application

Early detection of defects by performing batch inspection of various inspection areas at the production line.



- Molding • Casting: Wide-range, 3D inspection for dimension measurements (internal diameter, external form, diameter, concentricity)
- Semiconductors: Inspection for uneven surfaces and damage in silicon wafers • pattern reference
- Various Parts: Mass batch inspection without contact for bolts, wipers, screws, plastic parts, plastic bottles and rubber products

## Optical Specifications

### Telecentric Lens for 1/3" CCD Camera (diagonal 6 mm)

Model	Object Field (mm)	CCD (mm)	NA	Working Distance (WD) (mm)	Telecentric Range (mm)	Depth of Field (mm)	Magnification (X)	Measurement Field (mm)
18/6/0.05	18	6	0.05	66	+/-10	+/-3	0.33	10 x 14
35/6/0.1	35	6	0.1	67	+/-2.5	+/-7.5	0.17	20 x 27
70/6/0.1	70	6	0.1	113	+/-13	+/-25	0.086	41 x 55
105/6/0.1	105	6	0.1	182	+/-16	+/-50	0.057	62 x 82

### Telecentric Lens for 1/2" CCD Camera (diagonal 8 mm)

Model	Object Field (mm)	CCD (mm)	NA	Working Distance (WD) (mm)	Telecentric Range (mm)	Depth of Field (mm)	Magnification (X)	Measurement Field (mm)
11/8/0.01	11	8	0.01	160	+/-9	+/-6	0.72	6 x 8
35/8/0.1	35	8	0.1	64	+/-2	+/-4	0.228	21 x 28
70/8/0.1	70	8	0.1	103	+/-10.5	+/-16	0.114	43 x 55
105/8/0.1	105*	8	0.1	171	+/-12	+/-33	0.076	65 x 83
150/8/0.1	105*	8	0.1	225	+/-35	+/-75	0.05	93 x 118
225/8/0.1	225*	8	0.1	340	+/-55	+/-165	0.035	140 x 177
300/8/0.1	300*	8	0.1	450	+/-75	+/-300	0.026	187 x 236

### Telecentric Lens for 2/3" CCD Camera (diagonal 11 mm)

Model	Object Field (mm)	CCD (mm)	NA	Working Distance (WD) (mm)	Telecentric Range (mm)	Depth of Field (mm)	Magnification (X)	Measurement Field (mm)
11/11/0.02	11	11	0.02	54	+/-2.5	+/-1.25	1	6 x 8
11A/11/0.02	11A(Made-to-order)	11	0.02	17	+/-5	+/-1.25	1	6 x 8
11B/11/0.02	11B(Made-to-order)	11	0.02	54	+/-5	+/-1.25	1	6 x 8
13/11/0.01	13	11	0.01	65	+/-2	+/-1	0.846	8 x 10
22/11/0.05	22	11	0.05	66	+/-2.5	+/-2	0.5	13 x 17
22A/11/0.05	22A	11	0.05	56	+/-5	+/-2	0.5	13 x 17
35/11/0.1	35	11	0.1	58	+/-1.4	+/-2	0.314	21 x 28
70/11/0.1	70	11	0.1	75	+/-8	+/-9	0.157	43 x 55
105/11/0.1	105	11	0.1	121	+/-10	+/-20	0.104	65 x 83
150/11/0.1	150*	11	0.1	165	+/-25	+/-38	0.07	90 x 120
225/11/0.1	225*	11	0.1	250	+/-44	+/-90	0.048	135 x 180
300/11/0.1	300*	11	0.1	335	+/-55	+/-150	0.036	180 x 240

### Telecentric Lens for 1" CCD Camera (diagonal 16 mm) (Made-to-Order)

Model	Object Field (mm)	CCD (mm)	NA	Working Distance (WD) (mm)	Telecentric Range (mm)	Depth of Field (mm)	Magnification (X)	Measurement Field (mm)
8/16/0.08	8*	16	0.08	50	+/-1	+/-0.05	2	3 x 4
16/16/0.1	16*-LD	16	0.1	92	+/-2	+/-0.2	1	6 x 9
32/16/0.1	32*	16	0.1	78	+/-4	+/-0.8	0.5	13 x 17
70/16/0.1	70*	16	0.1	58	+/-4	+/-4	0.23	40 x 40
150/16/0.1	150*	16	0.1	110	+/-20	+/-17	0.1	86 x 86
300/16/0.1	300*	16	0.1	230	+/-40	+/-60	0.05	172 x 172

### Telecentric Lens for 1.1" CCD Camera (diagonal 18 mm)

Model	Object Field (mm)	CCD (mm)	NA	Working Distance (WD) (mm)	Telecentric Range (mm)	Depth of Field (mm)	Magnification (X)	Measurement Field (mm)
6/18/0.029	6	18	0.029	85	+/-1	+/-0.1	3	2 x 3

A = Object side lens (90° L-shaped type)  
B = Imaging side lens (90° L-shaped type)  
\* = Variable aperture model  
LD = Long working distance



## Peripherals CCD camera

Video output	Number of effective pixels
TV format	752 X 485
VGA	640 X 480
SVGA	800 X 600
XGA	1024 X 768
SXGA	1280 X 1024
UXGA	1600 X 1200

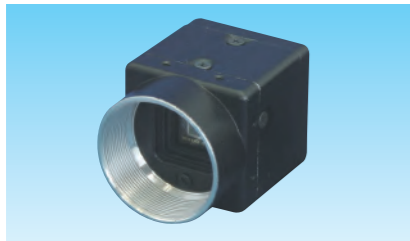

### STC-CL/CLC/A Series

Industry Smallest 28 x 28 mm CCD Camera

Progressive	Digital/Analog
Black and White/Color	VGA/XGA/SXGA/UXGA

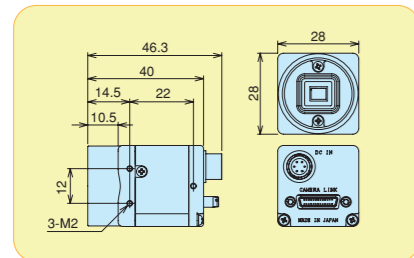

Model	Commodity Code	Model	Commodity Code
STC-CL33	A-1141	STC-CL152	A-1163
STC-CLC33	A-1142	STC-CLC152	A-1164
STC-A33	A-1143	STC-A152	A-1165
STC-CL83	A-1144	STC-CL202	A-1147
STC-CLC83	A-1145	STC-CLC202	A-1148
STC-A83	A-1146	STC-A202	A-1149

**STC-CL33/Black and White Camera Link**  
**STC-CLC33/Color Camera Link**  
**STC-A33/Black and White Analog**  
1/3 type progressive scan CCD  
Valid 330 thousand pixels  
Pixel size/7.4μm(H)×7.4μm(V)  
Frame rate/90fps  
Partial scan function/Arbitrary positioning/Line readout

**STC-CL83/Black and White Camera Link**  
**STC-CLC83/Color Camera Link**  
**STC-A83/Black and White Analog**  
1/3 type progressive scan CCD  
Valid 800 thousand pixels/1034(H)×768(V)  
Pixel size/4.65μm(H)×4.65μm(V)  
Frame rate/30fps  
Partial scan function/Arbitrary positioning/Line readout

**STC-CL152/Black and White Camera Link**  
**STC-CLC152/Color Camera Link**  
**STC-A152/Black and White Analog**  
1/2 type progressive scan CCD  
Valid 1.45 million pixels/1392(H)×1040(V)  
Pixel size/4.65μm(H)×4.65μm(V)  
Frame rate/19fps対応  
Partial scan function/Arbitrary positioning/Line readout

**STC-CL202/Black and White Camera Link**  
**STC-CLC202/Color Camera Link**  
**STC-A202/Black and White Analog**  
1/1.8 type progressive scan CCD  
Valid 2.01 million pixels/1628(H)×1236(V)  
Pixel size/4.40μm(H)×4.40μm(V)  
Frame rate/15fps  
Partial scan function/Arbitrary positioning/Line readout



### STC-USB Series

Digital USB2.0 output type

Progressive	Digital
B&W/Color	VGA/XGA

**STC-B33USB-AT: B&W VGA camera**  
**STC-C33USB-AT: Color VGA camera**  
1/3-inch progressive scan CCD  
Number of effective pixels: 330,000 (659H x 494V)  
Pixel size: 7.4H x 7.4Vμm  
Frame rate: 60 fps  
High-rate scan: 240 fps/80 lines max

**STC-B83USB-AT: B&W XGA camera**  
**STC-C83USB-AT: Color XGA camera**  
1/3-inch progressive scan CCD  
Number of effective pixels: 800,000 (1024H x 768V)  
Pixel size: 4.65μm(H) x 4.65μm(V)  
Frame rate: 30 fps  
High-rate scan: 120 fps/136 lines max

Model	Commodity code
STC-B33USB-AT	A-1150
STC-C33USB-AT	A-1151
STC-B83USB-AT	A-1152
STC-C83USB-AT	A-1153



### STC-1140 Series

120 fps, quadruple speed at high frame rate

Progressive	Digital
Black & White/Color	UXGA

**STC-CL1140: B&W VGA camera**  
**STC-CLC1140: Color VGA camera**

1/1.8 Type Progressive Scan CCD  
Valid 201 thousand pixels/1678 (H) x 1236 (V)  
Pixel size/4.40 um (H) x 4.40 um (V)  
Frame rate/support for 30 fps  
Support for each type of scanner mode  
Case size/28 mm (W) x 28 mm (H) x 47 mm (V)

Model	Commodity code
STC-CL232	A-1166
STC-CLC232	A-1167



### STC-N63 Series

Compact-housing color camera

TV Format	NTSC
Color	380 thousand pixels

**STC-N63 BJ / CJ**  
1/3-inch interline CCD  
Number of effective pixels: 380,000 (768H x 494V)  
Pixel size: 6.35H x 7.40Vμm  
Video output: VBS, Y/C

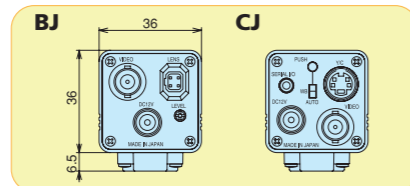

Model	Commodity code
STC-N63 BJ	A-1154
STC-N63 CJ	A-1161



### STC-620 Series

1/2-inch color camera of high sensitivity and definition

TV Format	NTSC
Color	380 thousand pixels

**STC-620 BJII / CC**  
1/2-inch interline CCD  
Number of effective pixels: 380,000 (768H x 494V)  
Pixel size: 8.4H x 9.8Vμm  
Video output: VBS, Y/C

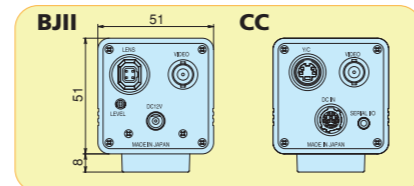

Model	Commodity code
STC-620 BJII	A-1155
STC-620 CC	A-1162

## Stand

### CCD camera stand

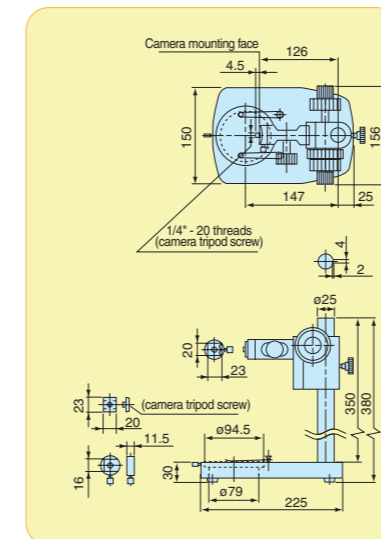
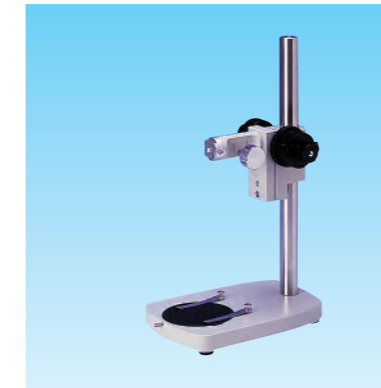

Model	Commodity code
MML-STD5A	A-0257

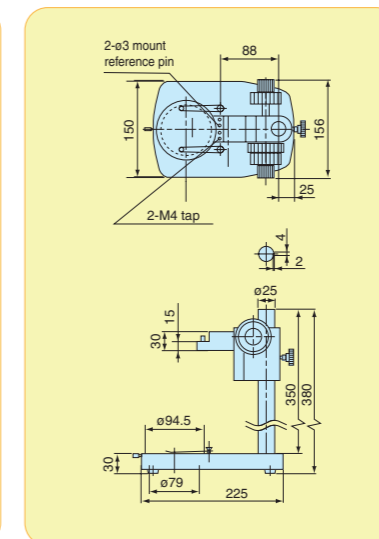

Model	Commodity code
MML-STD5B	A-0258

### Holder

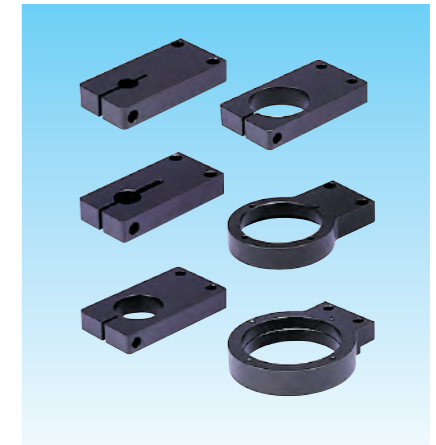

Model	Lens type	Commodity code
MML-HA12	Lens outside diameter ø12	A-0264
MML-HA16	Lens outside diameter ø16	A-0265
MML-HA33	Lens outside diameter ø33	A-0266
MML-HA40	Lens outside diameter ø40	A-0267
MML-HA62	ML-Z07545+D+PL	A-0268
MML-HA70	ML-Z0220D	A-0269

\*Use the parts in combination with MML-STD5B at left.

### XY micro motion stage

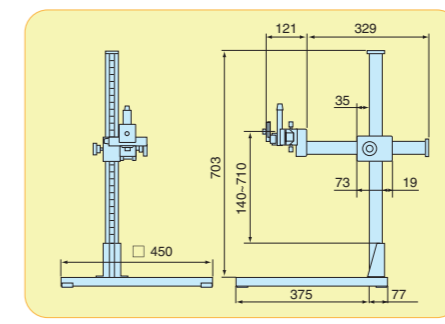

Model	Commodity code
MML-STD700	A-0275

\*Using the option, a straight light guide can be held. The holder can be fixed to the stand.

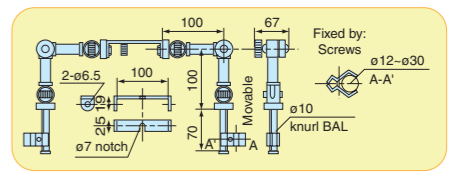

Model	Commodity code
MML-60EX	A-0276

### 3 Legged Screw Type Stand

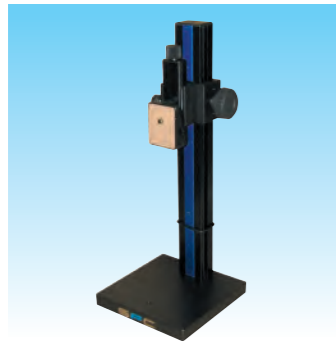

\*Standard pole height is 350 mm. However, 500 and 750 mm models are also available.

\*Ring LED and ring guide light can be held when using options. Fixture to the rear of the stand is possible using M3 screws.

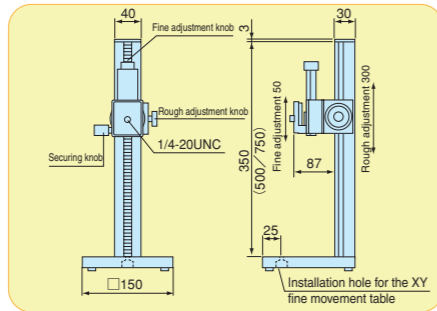

Model	Commodity Code
<b>MLH-50-L350</b>	A-0277
<b>MLH-50-L500</b>	A-0324
<b>MLH-50-L750</b>	A-0325

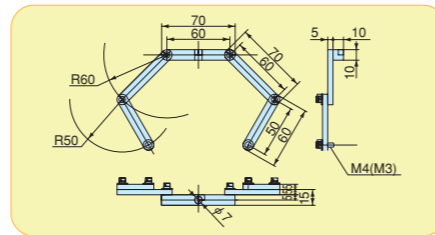

Model	Commodity Code
LED illumination device holder	A-0278

### MLH-FAC

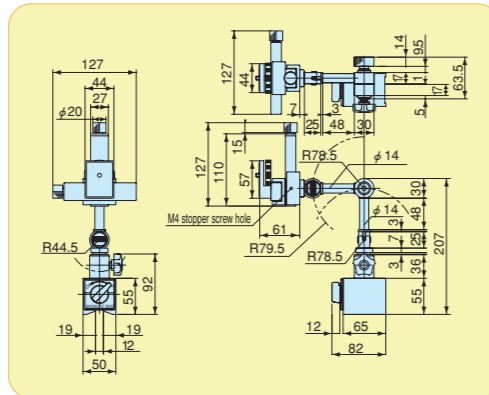

Model	Commodity Code
<b>MLH-FAC</b>	A-0326

### Stage

#### XY Stage

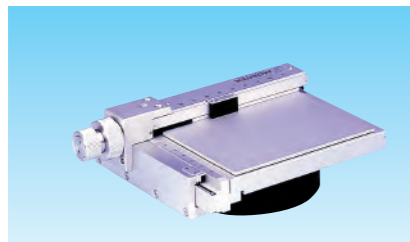

- Can be easily attached to MML-STD5A/5B.
- Perfect for simple experiments because it moves in both X and Y directions.

Model	Commodity code
<b>MML-XY2</b>	A-0284

#### Z tage



Model	Commodity code
<b>MML-STD-Z</b>	A-0285

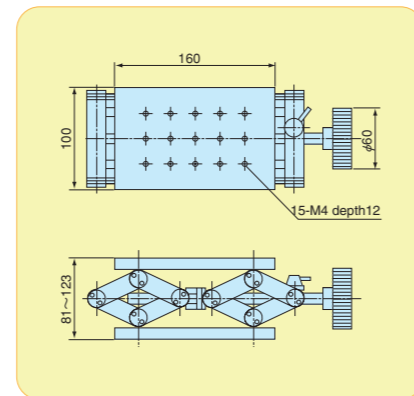

### Pole

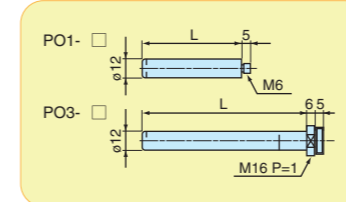
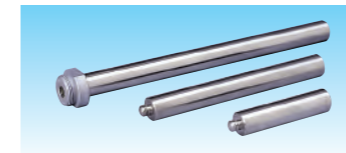

Model	Diameter	Length	Commodity code
<b>PO1-20</b>	12	20~80*1	—
<b>PO1-80</b>	12	80	—
<b>PO1-100</b>	12	100	A-0298
<b>PO1-120</b>	12	120	A-0299
<b>PO1-150</b>	12	150	A-0300
<b>PO1-200</b>	12	200	A-0301
<b>PO1-250</b>	12	250	A-0302
<b>PO1-300</b>	12	300	A-0303
<b>PO1-400</b>	12	400	A-0304
<b>PO1-500</b>	12	500	A-0305

\*1 Please specify in units of 10 mm.

Model	Diameter	Length	Commodity code
<b>PO3-100</b>	12	100	A-0306
<b>PO3-120</b>	12	120	A-0307
<b>PO3-150</b>	12	150	A-0308
<b>PO3-200</b>	12	200	A-0309
<b>PO3-250</b>	12	250	A-0310
<b>PO3-300</b>	12	300	A-0311
<b>PO3-400</b>	12	400	A-0312
<b>PO3-500</b>	12	500	A-0313

### Cross clamps

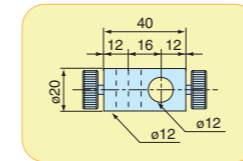
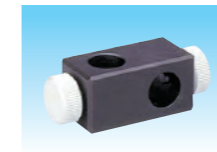

Model	Commodity code
<b>CL1-1212</b>	A-0314

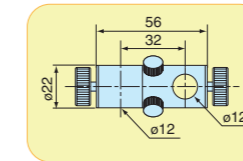

Model	Commodity code
<b>CL2-1212</b>	A-0315

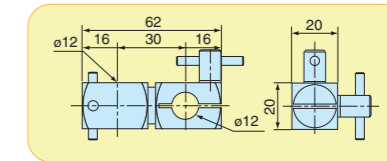

Model	Commodity code
<b>CL3-1212</b>	A-0316

### Fiber holder

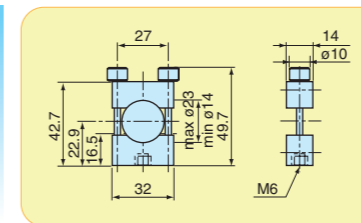

Model	Commodity code
<b>FC-01</b>	A-0317

### Magnet base

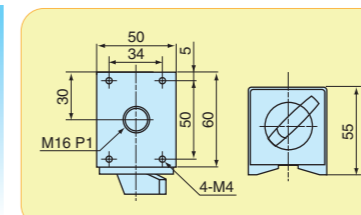

Model	Commodity code
<b>MGB-6050</b>	A-0318

## Light Guide Arm

Tripod type

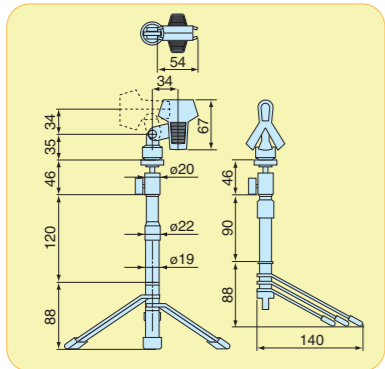

Model	Commodity code
<b>MLH-10</b>	A-0319

Clip type

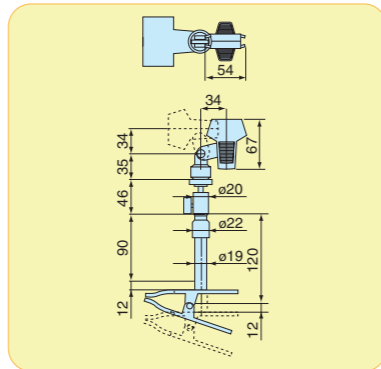

Model	Commodity code
<b>MLH-20</b>	A-0320

Interlock type

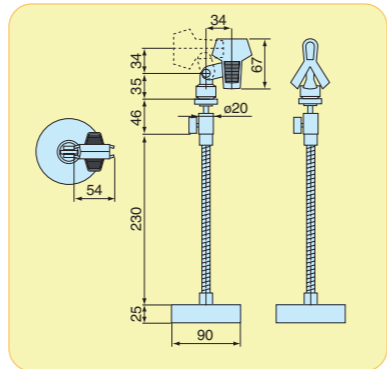

Model	Commodity code
<b>MLH-30</b>	A-0321

Arm type

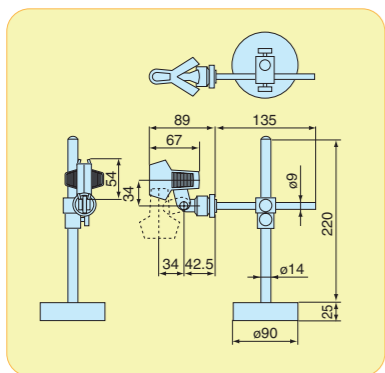

Model	Commodity code
<b>MLH-40</b>	A-0322

Magnet type

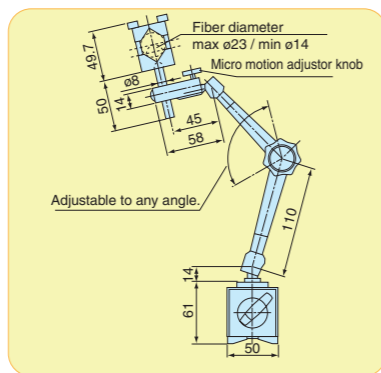

Model	Commodity code
<b>MLH-70</b>	A-0323

## Total optical illumination system

Infrared ray transmitting system

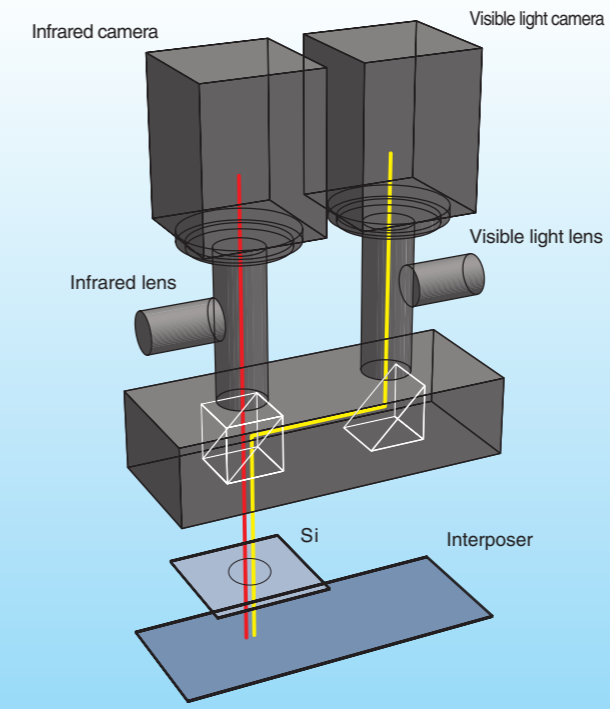

A total lens and lighting system that uses infrared rays to transmit through a Si, GaAs, or Ge substrate to recognize patterns on the backside.

YAG laser optical system

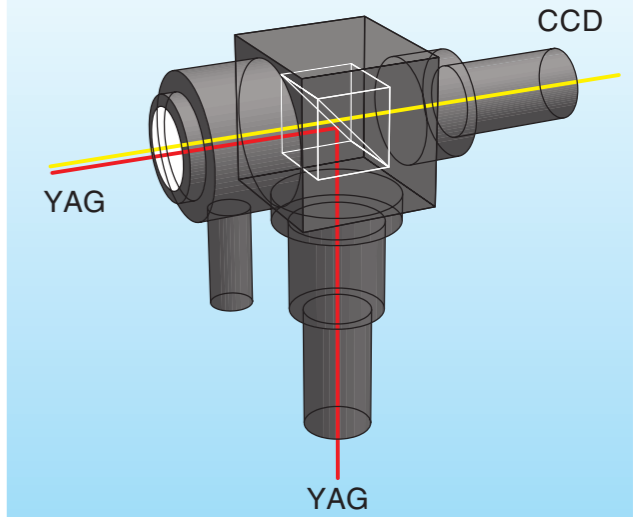

A space-saving optical system to check YAG laser welding and assembly on an optical path using a CCD.

Top and bottom double field optical system (1CCD method) (2CCD method)

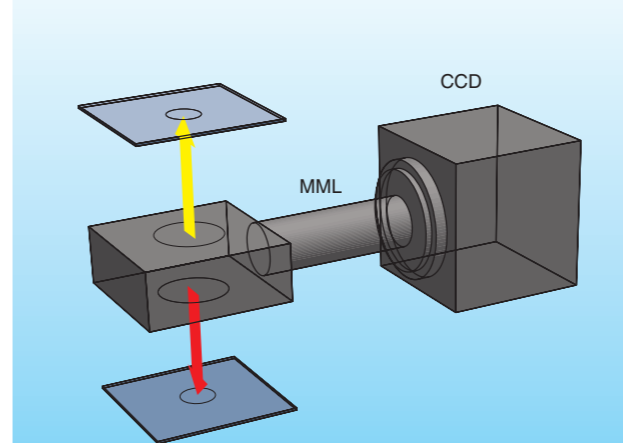

A space saving optical system to image two objects that are facing each other or one object at a 90 degree angle.

Twin-lens 2X magnification / twin-lens bifocal optical system

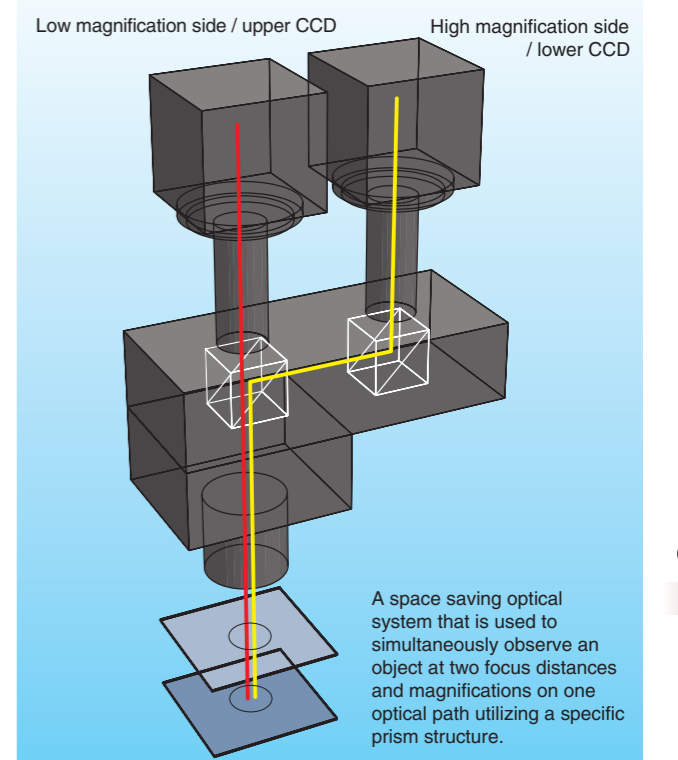

A space saving optical system that is used to simultaneously observe an object at two focus distances and magnifications on one optical path utilizing a specific prism structure.

Various OEM applications are available with combinations of more than 100 standard products and lights. Please contact us if you are interested.

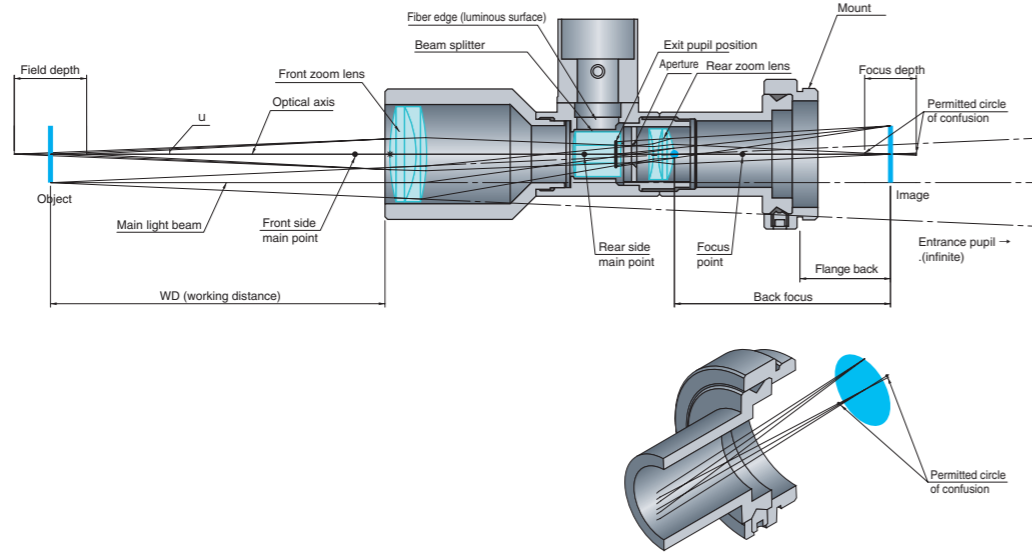

\*This diagram is intended for the purpose of explaining terminology. The positions and distances shown in this diagram are not necessarily accurate.

Performance	<b>Telecentric optical system</b>	<p>An optical system where the principal ray is parallel to the lens optical axis. An optical system where the light comes from an object toward a lens and stays parallel to the optical axis, even outside the axis, is called an object side telecentric optical system. A system where the light comes from a lens toward an image and stays parallel to the optical axis, even outside the axis, is called an image side telecentric optical system. Telecentric optical systems indicated in this catalog are object side telecentric optical systems.</p>
	<b>Resolution (μm)</b>	<p>Resolution is a measure of how closely spaced two points may be before they cannot be distinguished. For example, 1μm resolution means that two points that are 1 μm away from each other can be distinguished. Resolution values in this catalog are lenses' theoretical resolutions. The following is a formula to calculate theoretical resolution based on an aplanatic lens's ray diffraction. (Rayleigh formula)</p> $\text{Resolution} = \frac{0.61 \times \lambda}{NA}$ <p>λ: Wavelength, 0.61: Constant</p>
	<b>Resolving power (line/mm)</b>	<p>Resolving power indicates the number of black and white lines distinguished within 1mm in an image through a black and white grid-like chart lens. It is expressed by line/mm. For example, 100 line/mm means that black and white pitch 1/100mm (10 μm) can be distinguished. The width of both the black and white lines is 1/200mm (5μm).</p>
	<b>Horizontal TV resolution (TV line)</b>	<p>The total number of black and white horizontal stripes on a TV monitor screen. It is expressed in TV lines. For example, 200TV lines of horizontal TV resolution means that 100 white horizontal lines and 100 black horizontal lines can be distinguished on a TV monitor screen. When measuring resolving power, a pair of black and white lines is counted as one line. However, for TV lines, one pair is counted as 2TV lines. For example, if a 1/2-inch CCD camera is used with a lens of 50 lines/mm resolving power, horizontal TVV resolution on a TV monitor screen is calculated as follows; 50 x 6.4 (CCD width) x 2 = 640TV lines</p>
	<b>Distortion (%)</b>	<p>Lens's aberration where a straight object outside of the optical axis appears curved. Positive distortion of a straight line is called pincushion distortion while negative distortion is called barrel distortion.</p>
	<b>TV distortion (%)</b>	<p>Image distortion on a TV monitor. The closer to zero, the better the performance.</p> $\text{TV distortion (\%)} = \frac{\Delta h}{2h} \times 100$ <p>The curve amount on the long side is considered as distortion. Percentage of the depth of distortion Δh against vertical screen is TV distortion.</p>
	<b>Aperture efficiency Marginal light quantity (%)</b>	<p>Aperture efficiency indicates the brightness difference between the optical axis of the image formation plane and its surrounding area when an evenly bright object is captured with a lens. It is expressed by percent (%) assuming that the center brightness is 100. It is one of a lens's optical characteristics. Marginal light quantity in this catalog is aperture efficiency.</p>
	<b>Shading (%)</b>	<p>Shading is the brightness difference between TV monitor's center and its edges when an evenly bright object is captured with a lens and CCD-TV camera. It is expressed by percent (%). Generally, this percentage is calculated based on power ratio of light receiving elements and CCD elements. Shading indicates comprehensive performance of a lens and TV camera. To make shading small, telecentric optical system is used.</p>
	<b>Chromatic aberration</b>	<p>In lenses' optical systems, positions where images are formed and image magnification differ according to light's wavelength. Rays with different wavelengths have different colors. This is called chromatic aberration. Aberration on the optical axis is called chromatic aberration on the axis and magnification difference is called magnification chromatic aberration.</p>

Distance	<b>WD (Working Distance) (mm)</b>	Distance from the front end of a lens system to the object under inspection.							
	<b>Focal length f (mm) Back focus / front focus</b>	Focal length is the distance from the optical system's principle point to the focal point. Distance from the vertex of the last lens to the back focal point is called back focal length. Distance from the vertex of the first lens to the front focal point is called front focal length.							
	<b>Depth of field</b>	<p>Depth is the distance between the nearest and farthest points that appear in acceptably sharp focus when an object is shifted back and force from the best focal point. Depth range of the object side is called depth of field.</p> <p><b>Depth of field = 2 ( permissible circle of confusion x effective Fno ÷ magnification<sup>2</sup> )</b></p> <p>Images through lenses theoretically form as points. Acceptable blur on an acceptably clear image is called the permissible circle of confusion</p>							
	<b>Depth of focus</b>	Depth is the distance between the nearest and farthest points that appear in acceptably sharp focus when a CCD is shifted back and force from the best focal point. Depth range of the image side is called depth of focus.							
	<b>Flange back (mm)</b>	Distance from the front of the camera mount thread to the image plane.							
	<b>C-mount standard</b>	<table border="1"> <thead> <tr> <th>Name</th> <th>Basic outside diameter</th> <th>No. of screw threads (for 25.4mm)</th> <th>Flange back</th> </tr> </thead> <tbody> <tr> <td>U1</td> <td>25.400mm</td> <td>32 threads</td> <td>17.526mm</td> </tr> </tbody> </table>	Name	Basic outside diameter	No. of screw threads (for 25.4mm)	Flange back	U1	25.400mm	32 threads
Name	Basic outside diameter	No. of screw threads (for 25.4mm)	Flange back						
U1	25.400mm	32 threads	17.526mm						
Brightness	<b>Numerical aperture NA, NA'</b>	<p>When the half angle that an object makes on the entrance pupil is u and refractive index is n, n x sin u is called object side numerical aperture, NA. When the half angle that an image makes on exit pupil is u' and refractive index is n', n' x sin u' is called image side numerical aperture, NA'.</p> <p>NAs in this catalog indicate object side numerical apertures. Numerical aperture is an important value that expresses a lens's resolution and brightness.</p> <p><b>NA=n x sin u    NA'=n' x sin u'</b></p> <p>The higher the NA, the greater the resolution and brightness are.</p>							
	<b>F Number F No</b>	<p>The value indicates a lens's brightness. It is calculated by dividing the lens's focal length by the lens's effective diameter (entrance pupil D mm) looking from object side. It can be also calculated by NA and lens's optical magnification (β). The smaller the number the brighter the lens is.</p> <p><b>F No=f/D</b></p>							
	<b>Effective F No</b>	<p>The value indicates a lens's brightness when an object is located in finite distance, namely its actual brightness. The higher the optical magnification (β), the darker the lens is.</p> <p><b>Effective F No=β/(2 x NA)=(1 x NA')</b></p> <p><b>Effective F No=(1+β) x F No *</b></p> <p>* Approximation for thin-walled systems</p>							
	<b>Optical magnification β</b>	<p>Image size ratio against the object size.</p> <p><b>β = y'/y = b/a = NA/NA' = CCDcamera element size /actual size of field of view</b></p>							
Magnification	<b>Electronic magnification</b>	Electronic magnification is a magnification of an image on a CCD camera when it is displayed on a monitor screen.							
	<b>Monitor magnification</b>	<p>Monitor magnification is a magnification of an object displayed on a monitor screen through a lens.</p> <p><b>Monitor magnification = (optical magnification β) x (electronic magnification)</b></p> <p>(Calculation example) Optical magnification β=0.2x, CCD size 1/2" (diagonal line 8mm), monitor 14" :                      Electronic magnification = 14 x 25.4 ÷ 8 = 44.45(times)                      Monitor magnification = 0.2 x 44.45= 8.89(times) (inch = 25.4mm)</p>							
	<b>Field of view</b>	<p>Field of view is the size of a viewed object that can be taken when the lens is attached to a CCD-TV camera. The size of field of view is (CCD format size) / (optical magnification β).</p> <p>(Calculation example) Optical magnification β=0.2x, CCD size 1/2" (4.8mm long, 6.4mm wide) :                      Size of field of view Length = 4.8/0.2 = 24(mm)                      Width = 6.4/0.2 = 32(mm)</p>							

### CCD camera element size

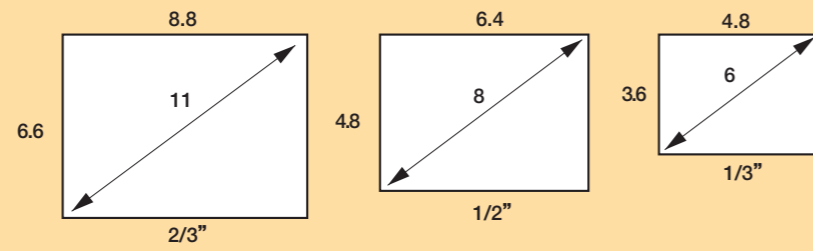

### Formula

$$\begin{aligned} \text{Resolution}(\mu\text{m}) &= 0.61 \text{ (fixed number)} \times 0.55 \text{ (design wavelength)} / \text{NA} \\ \text{Effective Fno} &= \text{magnification} / 2\text{NA} \\ \text{Depth of field (mm)} &= 2 \text{ (permissible circle of confusion)} \times \text{effective Fno} / \text{magnification}^2 \\ \text{Luminous flux diameter} &= 2\text{NA} \times \text{height from a object} + \text{field size (angle)} \end{aligned}$$

### Telecentric optical system's features

#### Non-telecentric lens

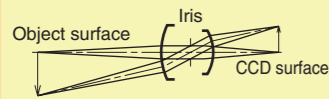

- Pros**
- Smaller size.
  - Cost-saving because the number of lenses is fewer.
- Cons**
- Object size or position varies as the object surface goes up and down.

#### Object side telecentric lens



- Pros**
- Object size does not change even when the object surface goes up and down.
  - Smaller size is possible because coaxial episcopic illumination is used.
- Cons**
- The lens is larger than regular lenses if coaxial episcopic illumination is not used.

#### Double-sided telecentric lens

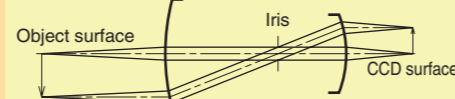

- Pros**
- Similar to MMLs, accuracy is high when the size of the back of the camera flange differs greatly.
- Cons**
- Same as MMLs. More expensive than MMLs.

### Attachment Example

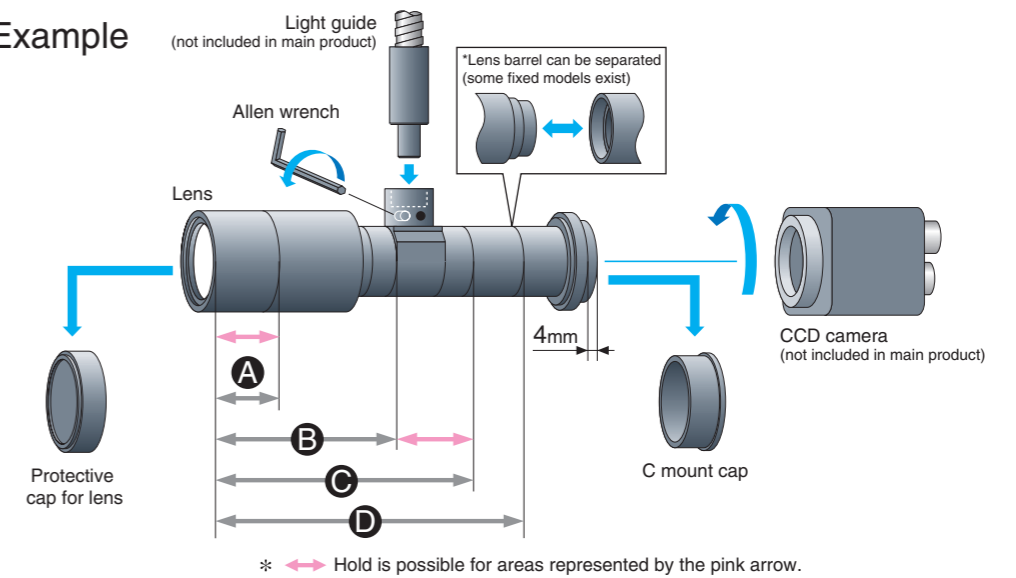

### Chart for Holding Possibility and Separation Positions

Model	A	B	C	D
<b>ST40 Series</b>				
MML1-ST40D	11	17	34	37
MML1-ST40	11	17	34	
MML1.5-ST40D	10	14	30	34
MML1.5-ST40	10	14	30	
MML2-ST40D	9	12	27	32
MML2-ST40	9	12	27	
MML3-ST40D	9	12	27	32
MML3-ST40	9	12	27	
MML4-ST40D	10	10	27	31
MML4-ST40	10	10	27	
MML6-ST40D	10	10	27	31
MML6-ST40	10	10	27	
MML8-ST40D	10	10	27	31
MML8-ST40	10	10	27	
<b>ST65 Series</b>				
MML08-ST65D	15	39	62	59
MML08-ST65	15	39	62	
MML1-ST65D	15	33	53	53
MML1-ST65	15	33	53	
MML1.5-ST65D	11	23	41	44
MML1.5-ST65	11	23	41	
MML2-ST65D	15	25	46	46
MML2-ST65	15	25	46	
MML4-ST65D	20	26	47	85
MML4-ST65	20	26	47	
MML6-ST65D	20	30	47	100
MML6-ST65	20	30	47	
MML2-ST65DS	9	20	40	40
MML2-ST65S	9	20	40	
MML3-ST65DS	10	17	47	38
MML3-ST65S	10	17	47	
MML4-ST65DS	9	18	34	55
MML4-ST65S	9	18	34	
MML6-ST65DS	9	18	55	55
MML6-ST65S	9	18	55	
MML8-ST65DS	9	18	55	55
MML8-ST65S	9	18	55	

Model	A	B	C	D
<b>ST110 Series</b>				
MML08-ST110D	20	65	93	85
MML08-ST110	20	65	93	
MML1-ST110D	20	50	75	75
MML1-ST110	20	50	75	
MML2-ST110D	20	44	68	64
MML2-ST110	20	44	68	
MML4-ST110D	15	29	68	49
MML4-ST110	15	29	68	
MML6-ST110D	15	29	68	49
MML6-ST110	15	29	68	
MML8-ST110D	15	29	68	49
MML8-ST110	15	29	68	
MML2-ST110DS	12	27	50	48
MML2-ST110S	12	27	50	
MML3-ST110DS	12	27	50	48
MML3-ST110S	12	27	50	
<b>Other ST</b>				
MML1-ST150D	10	74	91	91
MML1-ST150	10	74	91	
MML08-ST170D	10	74	91	91
MML08-ST170	10	74	91	
MML1-ST300D	25	100	150	190

Model	A	B	C	D
<b>HR65 Series</b>				
MML05-HR65D	10	25	69	61
MML05-HR65	10	25	69	
MML1-HR65D	15	33	53	53
MML1-HR65	15	33	53	
MML1.5-HR65D	11	23	41	44
MML1.5-HR65	11	23	41	
MML2-HR65D	15	25	46	46
MML2-HR65	15	25	46	
MML4-HR65D	20	26	47	86
MML4-HR65	20	26	47	
MML6-HR65D	20	30	47	100
MML6-HR65	20	30	47	
<b>HR110 Series</b>				
MML05-HR110D	11	67	102	93
MML05-HR110	11	67	102	
MML08-HR110D	20	65	91	82
MML08-HR110	20	65	91	
MML1-HR110D	30	64	95	81
MML1-HR110	30	64	95	
MML1.5-HR110D	13	50	76	72
MML1.5-HR110	13	50	76	
MML2-HR110D	20	43	70	68
MML2-HR110	20	43	70	
MML4-HR110D	20	94	120	107
MML4-HR110	20	94	120	
MML6-HR110D	15	105	120	110
MML6-HR110	15	105	120	

MML field of view list

Optical magnification	2/3" (length x width x angle)	Monitor magnification		1/2" (length x width x angle)	Monitor magnification		1/3" (length x width x angle)	Monitor magnification	
		9"	14"		9"	14"		9"	14"
x 0.1	66 x 88 x 110	2.1	3.2	48 x 64 x 80	2.9	4.5	36 x 48 x 60	3.8	5.9
x 0.14	47 x 63 x 79	2.9	4.5	34 x 46 x 57	4.0	6.2	26 x 34 x 43	5.3	8.3
x 0.16	41 x 55 x 69	3.4	5.2	30 x 40 x 50	4.6	7.1	23 x 30 x 38	6.1	9.5
x 0.18	37 x 49 x 61	3.8	5.8	27 x 36 x 44	5.1	8.0	20 x 27 x 33	6.9	10.7
x 0.2	33 x 44 x 55	4.2	6.5	24 x 32 x 40	5.7	8.9	18 x 24 x 30	7.6	11.9
x 0.3	22 x 29 x 37	6.3	9.7	16 x 21 x 27	8.6	13.4	12 x 16 x 20	11.4	17.8
x 0.4	17 x 22 x 28	8.4	12.9	12 x 16 x 20	11.4	17.8	9 x 12 x 15	15.2	23.7
x 0.5	13 x 18 x 22	10.5	16.2	9.6 x 12.8 x 16	14.3	22.3	7.2 x 9.6 x 12	19.1	29.7
x 0.6	11 x 15 x 18	12.6	19.4	8.0 x 10.7 x 13	17.2	26.7	6 x 8 x 10	22.9	35.6
x 0.7	9 x 13 x 16	14.7	22.6	6.9 x 9.1 x 11	20.0	31.2	5.1 x 6.9 x 8.6	26.7	41.5
x 0.75	9 x 12 x 15	15.8	24.2	6.4 x 8.5 x 11	21.5	33.4	4.8 x 6.4 x 8.0	28.6	44.5
x 0.8	8 x 11 x 14	16.8	25.8	6.0 x 8.0 x 10	22.9	35.6	4.5 x 6.0 x 7.5	30.5	47.4
x 0.9	7.3 x 9.8 x 12.2	18.9	29.1	5.3 x 7.1 x 8.9	25.7	40.1	4.0 x 5.3 x 6.7	34.3	53.4
x 1	6.6 x 8.8 x 11.0	21.0	32.3	4.8 x 6.4 x 8.0	28.6	44.5	3.6 x 4.8 x 6.0	38.1	59.3
x 1.5	4.4 x 5.9 x 7.3	31.5	48.5	3.2 x 4.3 x 5.3	42.9	66.8	2.4 x 3.2 x 4.0	57.2	89.0
x 2	3.3 x 4.4 x 5.5	42.0	64.6	2.4 x 3.2 x 4.0	57.2	89.0	1.8 x 2.4 x 3.0	76.2	119
x 2.5	2.6 x 3.5 x 4.4	52.5	80.8	1.9 x 2.6 x 3.2	71.5	111	1.4 x 1.9 x 2.4	95.3	148
x 3	2.2 x 2.9 x 3.7	63.0	96.9	1.6 x 2.1 x 2.7	85.8	134	1.2 x 1.6 x 2.0	114	178
x 3.5	1.9 x 2.5 x 3.1	73.5	113	1.4 x 1.8 x 2.3	100	156	1.0 x 1.4 x 1.7	133	208
x 4	1.7 x 2.2 x 2.8	84.0	129	1.2 x 1.6 x 2.0	114	178	0.9 x 1.2 x 1.5	152	237
x 4.5	1.5 x 2.0 x 2.4	94.5	145	1.1 x 1.4 x 1.8	129	200	0.8 x 1.1 x 1.3	171	267
x 5	1.3 x 1.8 x 2.2	105	162	1.0 x 1.3 x 1.6	143	223	0.7 x 1.0 x 1.2	191	297
x 6	1.1 x 1.5 x 1.8	126	194	0.8 x 1.1 x 1.3	172	267	0.6 x 0.8 x 1.0	229	356
x 7	0.94 x 1.26 x 1.57	147	226	0.69 x 0.91 x 1.14	200	312	0.51 x 0.69 x 0.86	267	415
x 8	0.83 x 1.10 x 1.38	168	258	0.60 x 0.80 x 1.00	229	356	0.45 x 0.60 x 0.75	305	474
x 9	0.73 x 0.98 x 1.22	189	291	0.53 x 0.71 x 0.89	257	401	0.40 x 0.53 x 0.67	343	534
x 10	0.66 x 0.88 x 1.10	210	323	0.48 x 0.64 x 0.80	286	445	0.36 x 0.48 x 0.60	381	593
x 11	0.60 x 0.80 x 1.00	231	355	0.44 x 0.58 x 0.73	315	490	0.33 x 0.44 x 0.55	419	652
x 12	0.55 x 0.73 x 0.92	252	388	0.40 x 0.53 x 0.67	343	534	0.30 x 0.40 x 0.50	457	712